

# 6252335COM 3 Drawer Dresser

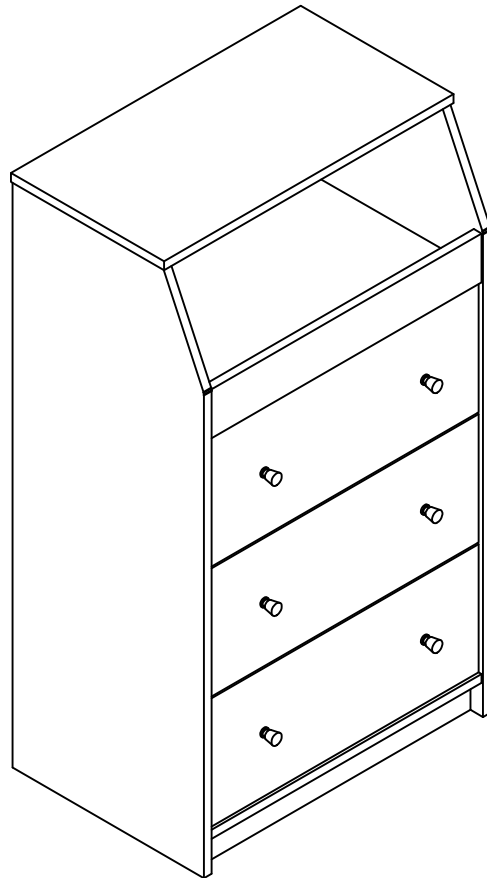

Date of Purchase \_\_\_ / \_\_\_ / \_\_\_  
Lot Number:

B346252335COM0



**Do Not Return This Product!**  
Contact our customer service team for help first.  
**Call:** 1-800-489-3351 (toll free)  
Monday-Friday 9am - 5pm CST  
**Visit:** [www.ameriwoodhome.com](http://www.ameriwoodhome.com)

THIS INSTRUCTION BOOKLET CONTAINS **IMPORTANT** SAFETY INFORMATION. PLEASE READ AND KEEP FOR FUTURE REFERENCE.

## Secure Your Furniture

Keep your home and family safe with the wall anchor kit that is included with the product.

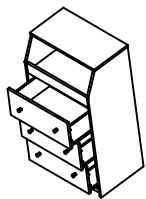

Serious or fatal crushing injuries can occur from tipping furniture.

**WARNING:** Manufacturer assumes no liability for improper installation or excessive loads placed on screws or bracket. This wall anchor is not a substitute for proper adult supervision.



Follow Ameriwood Home



# Contact Us!

## Do NOT return this product!

Contact our friendly customer service team first for help.



Visit [ameriwoodhome.com](http://ameriwoodhome.com) to view the limited warranty valid in the U.S. and Canada.

Assembly Tips



# Helpful Hints

PEOPLE NEEDED FOR ASSEMBLY: 1-2

- Open your item in the area you plan to keep it to avoid excessive heavy lifting.
- Identify, sort and count the parts before attempting assembly.
- Compression dowels are lightly tapped in with a hammer.
- Slides are labeled with a **R** (right) and **L** (left) for proper placement.
- Make sure to always face the point on the top of the Cam Lock towards the outer edge.
- Use all the nails provided for the back panel and spread them out equally.
- Back panel must be used to make sure your unit is sturdy.
- Do NOT use harsh chemicals or abrasive cleaners on this item.
- Never push, pull, or drag your furniture.



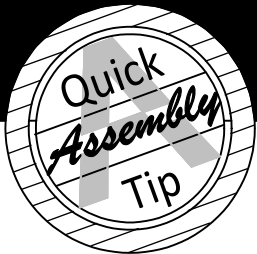

## Before You Start



- ✓ Read through each step carefully and follow the proper order
- ✓ Separate and count all your parts and hardware  
Parts are labeled on the surface or edge of the part
- ✓ Give yourself enough room for the assembly process
- ✓ Have the following tools: Flat Head Screwdriver, #2 Phillips Head Screwdriver and Hammer
- ✓ Caution: If using a power drill or power screwdriver for screwing, please be aware to slow down and stop when screw is tight. Failure to do so may result in stripping the screw.

## Cam Lock Fastening System

This Cam Lock Fastening System will be used throughout the assembly process.

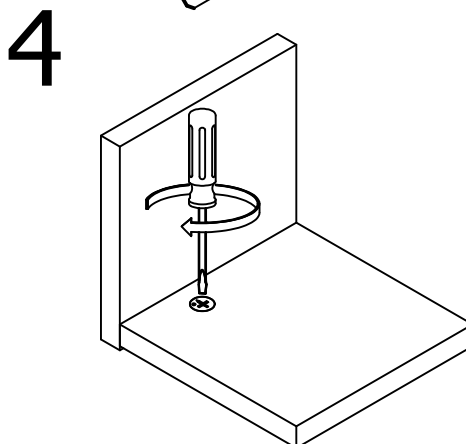
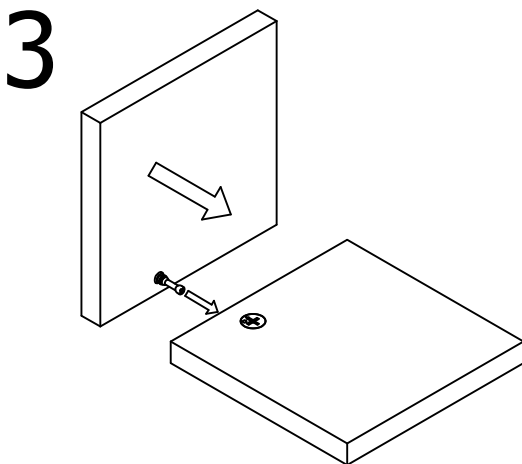
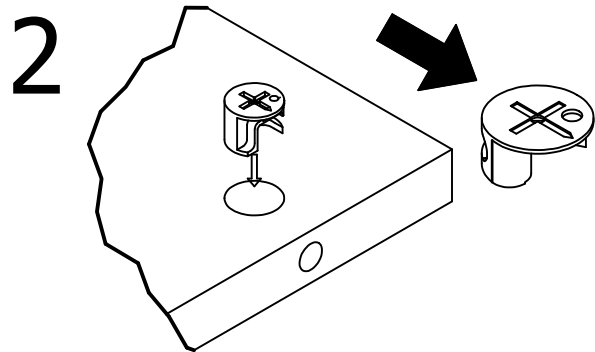
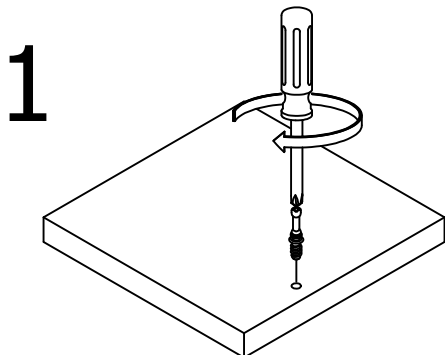

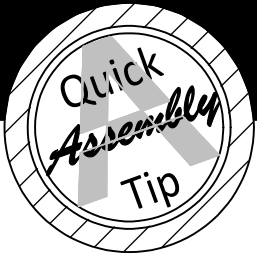

# Before You Start

Please Note:

You may need to lightly tap the wood dowels into the holes during your assembly process.

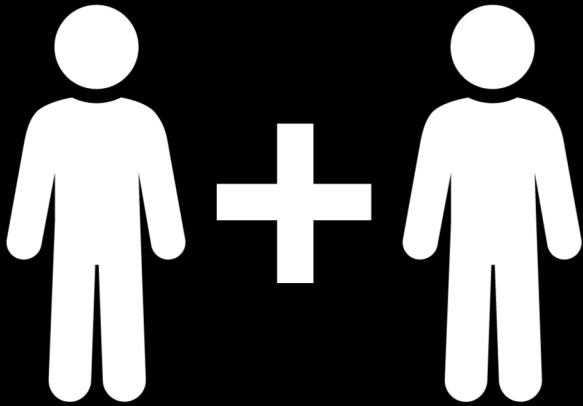
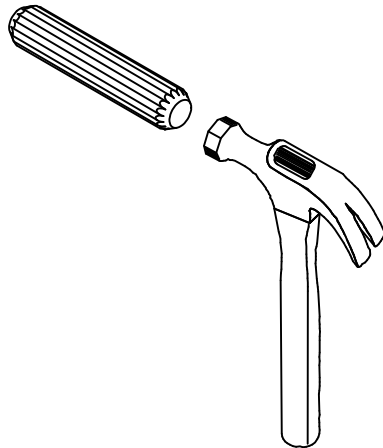

**2 PEOPLE NEEDED FOR ASSEMBLY**

**2 PERSONAS NECESITADAS  
PARA LA ASAMBLEA**

**2 PERSONNES NÉCESSAIRES  
POUR L'ASSEMBLAGE**

**CAUTION:** Failure to use 2 people for assembly could result in unit damage or personal injury.

**PRECAUCIÓN:** Si no se utilizan 2 personas para el ensamblaje, se pueden producir daños en la unidad o lesiones personales.

**ATTENTION:** Échec d'utiliser 2 personnes pour l'assemblage peut causer du dommage au meuble ou causer des blessures.

# Board Identification

Not actual size

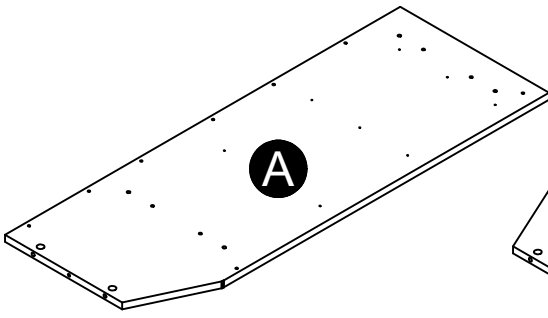

Left Panel  
36252335010

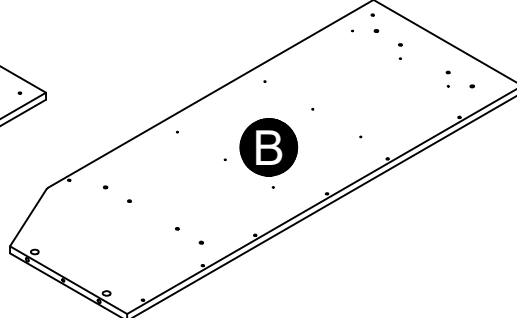

Right Panel  
36252335020

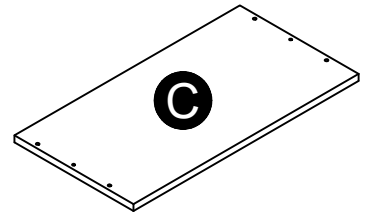

Top  
36252335030

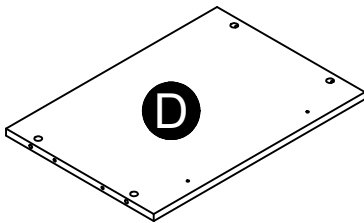

Bottom  
36252335040

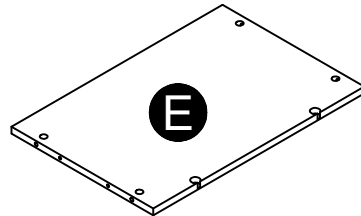

Shelf  
36252335050

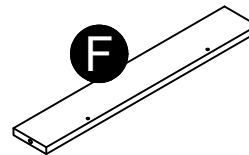

Front Rail  
36252335060

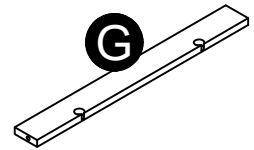

Kick  
36252335070

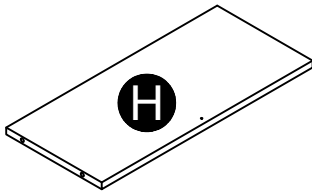

Upper Back  
36252335080

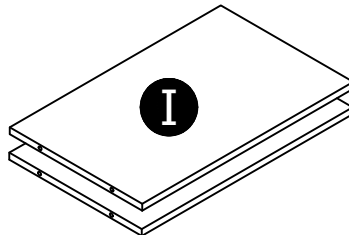

Lower Back (x2)  
36252000090

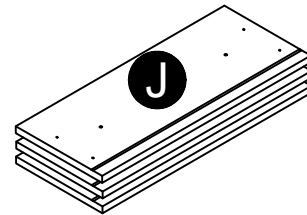

Drawer Front (x3)  
36252335100

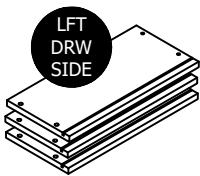

Left Drawer Side (x3)  
39991167346410L

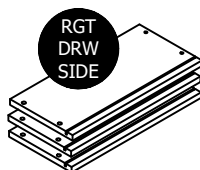

Right Drawer Side (x3)  
39991167346410R

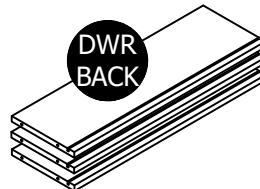

Drawer Back (x3)  
39991167051217B

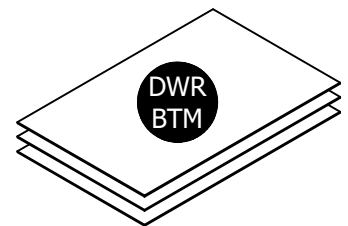

Drawer Bottom (x3)  
39991340052310D

# Board Identification

Not actual size

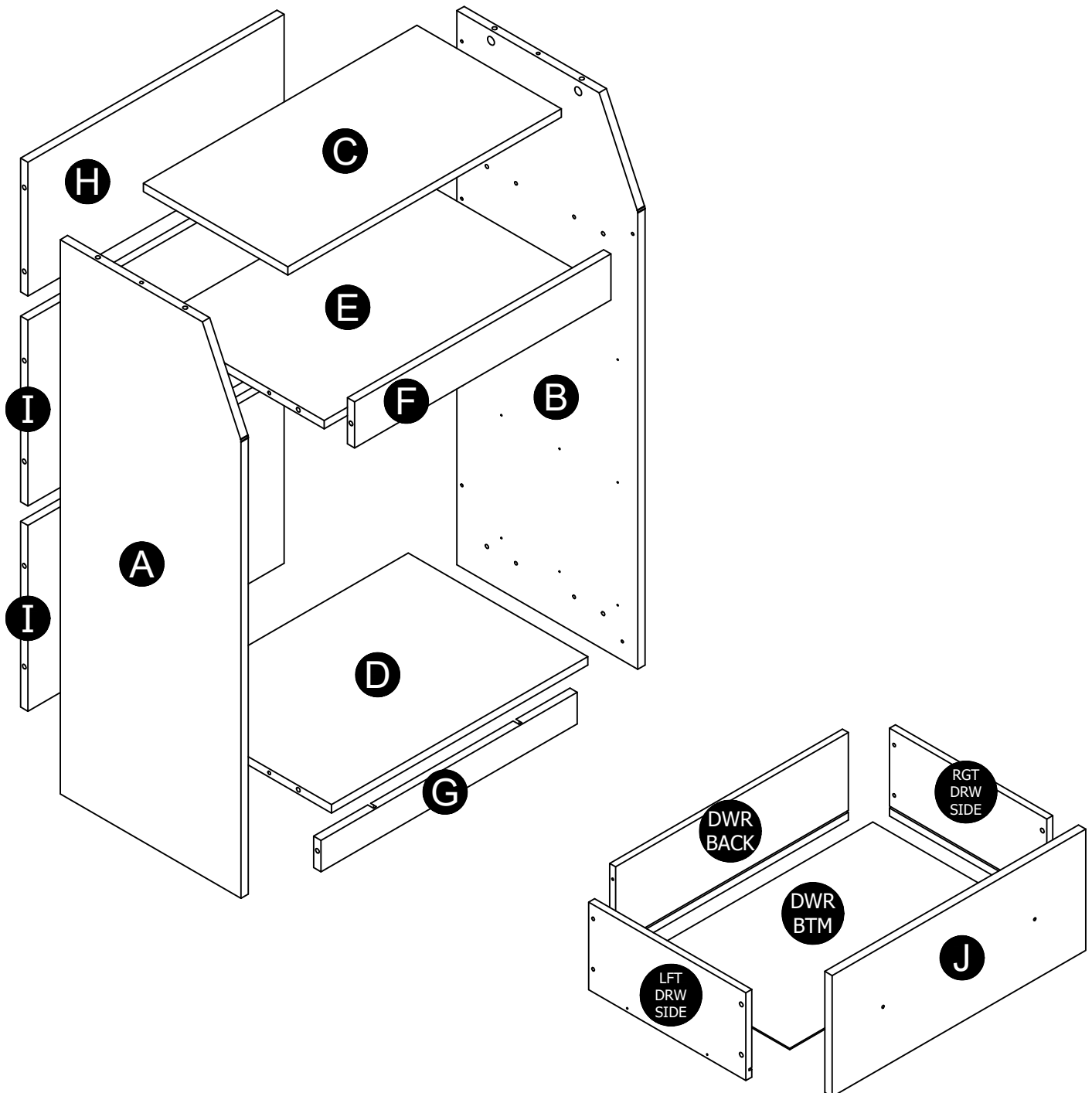

## Part List

Actual Size

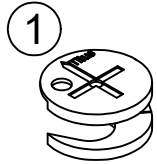

(x12)  
#A22570  
cam lock



(x12)  
#A22510  
cam bolt



(x10)  
#A21670  
wood dowel

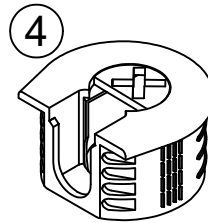

(x4)  
#A22820  
connector



(x4)  
#A22810  
connector bolt



(x30)  
#A11080  
7/16" screw



(x16)  
#A21960  
hidden fastener



(x24)  
#A12120  
7/16" screw



(x6)  
#A17400  
7/8" bolt

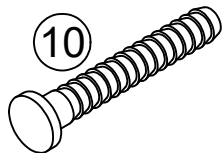

(x12)  
#A21975  
drive fastener

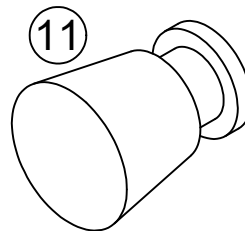

(x6)  
#A50265  
knob

# Part List

Not actual size

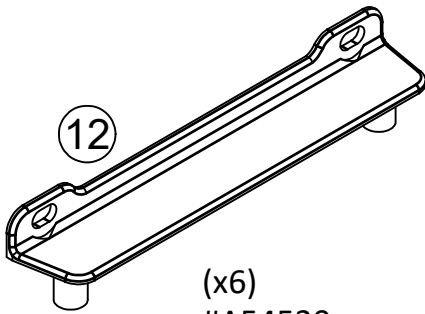

(x6)  
#A54520  
drawer bracket

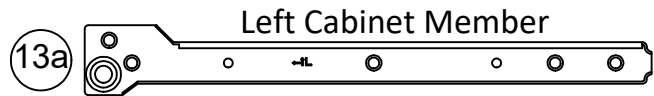

Left Cabinet Member

13a

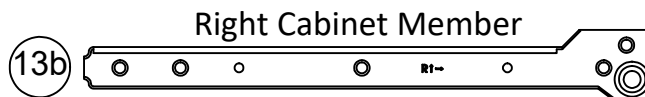

Right Cabinet Member

13b

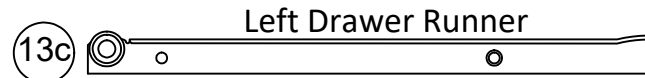

Left Drawer Runner

13c

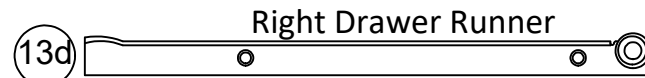

Right Drawer Runner

13d

(x3)  
13 #A56720  
slide

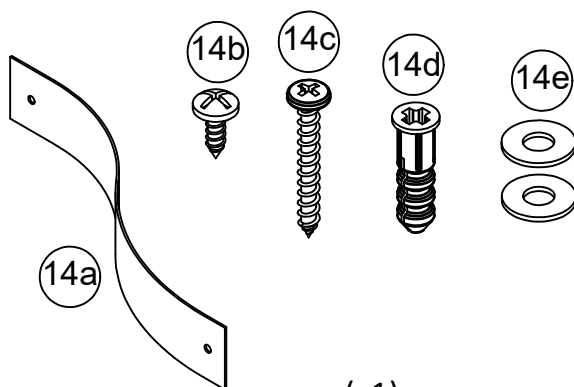

(x1)  
14 #A84000  
safety strap kit



## STEP 1

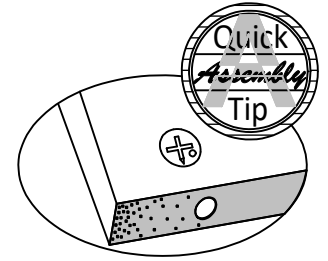
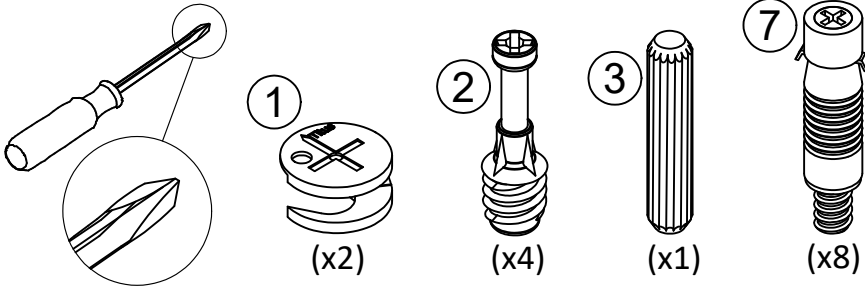

Proper orientation of CAM LOCK

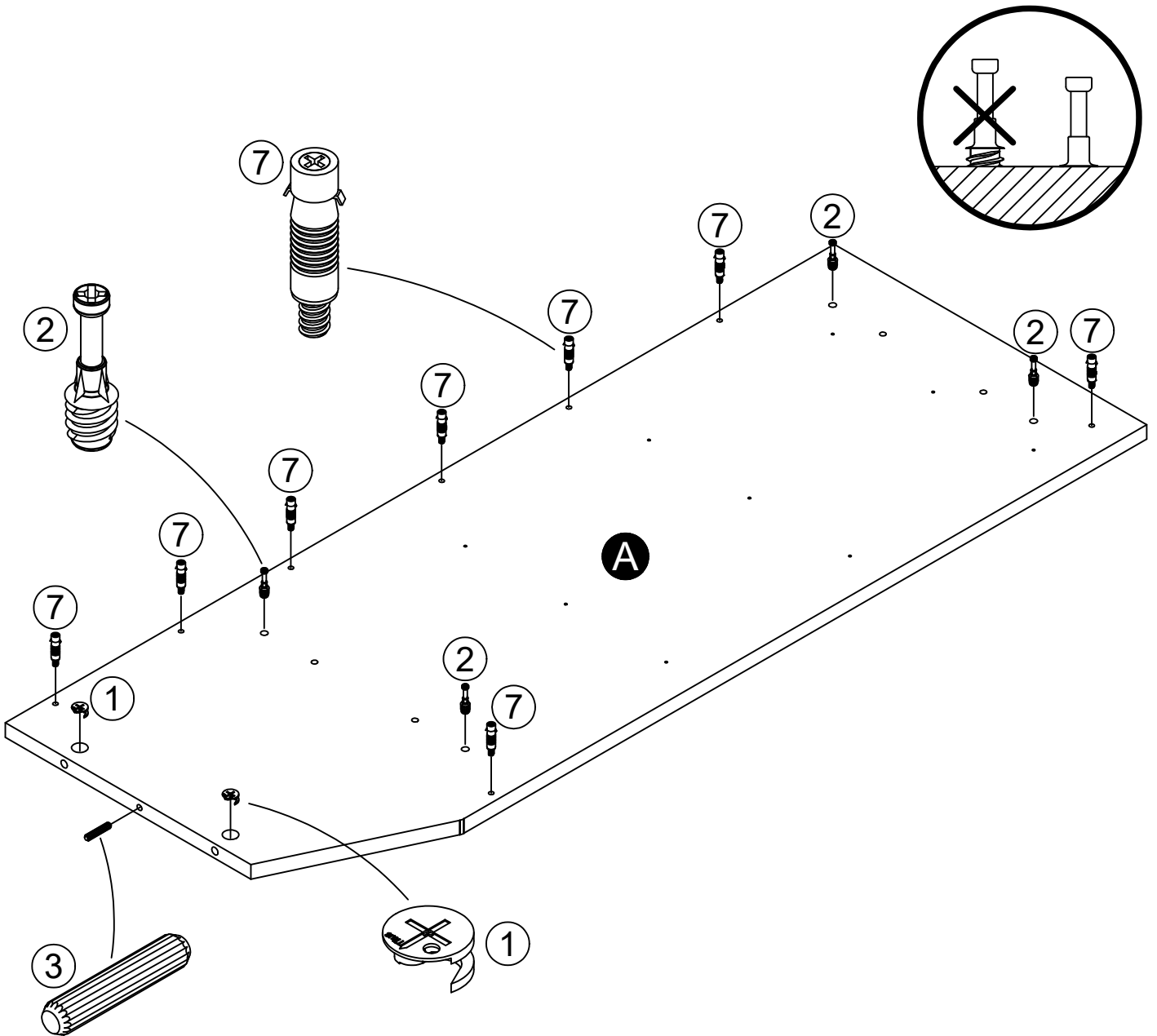

## STEP 2

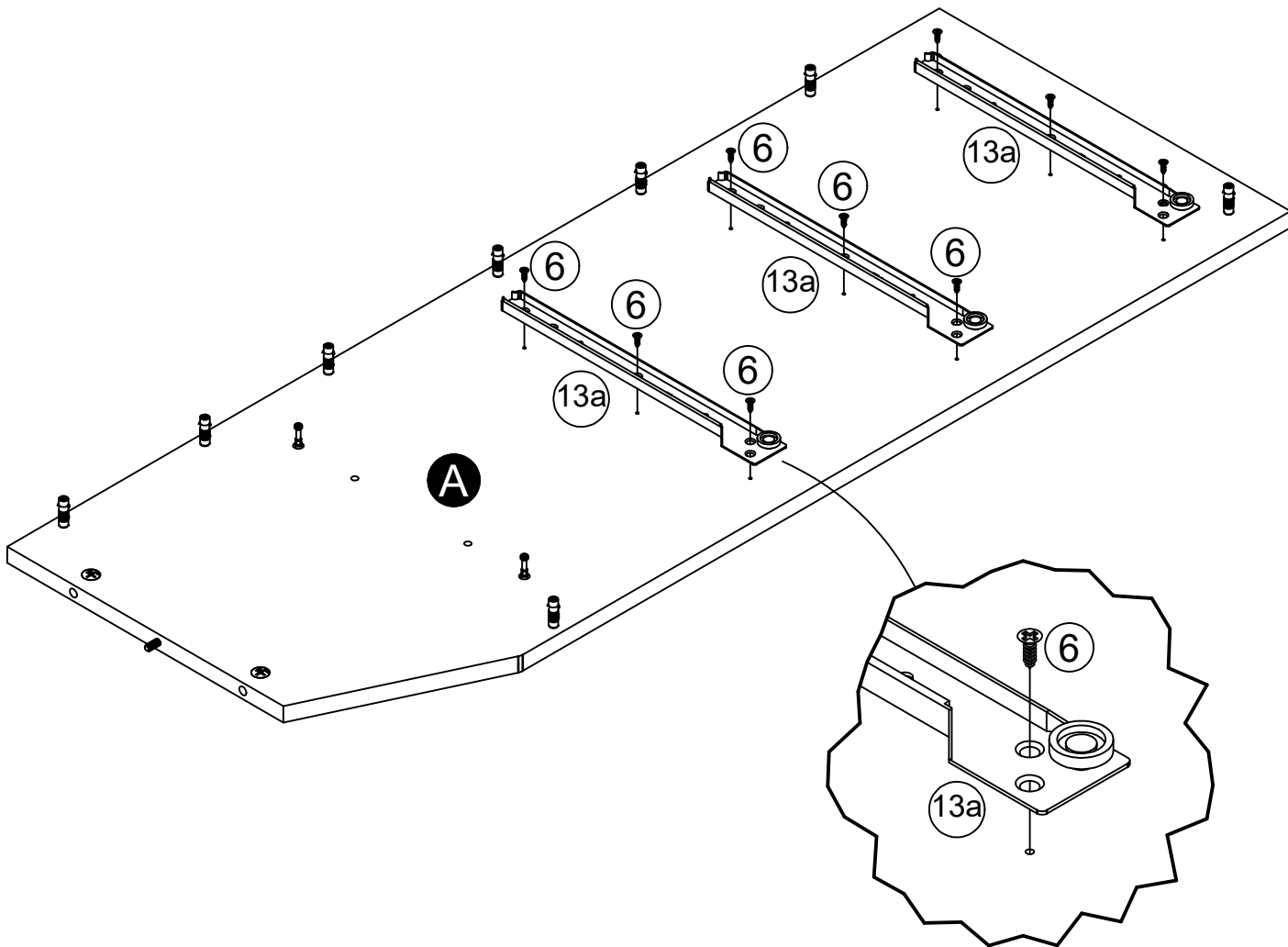
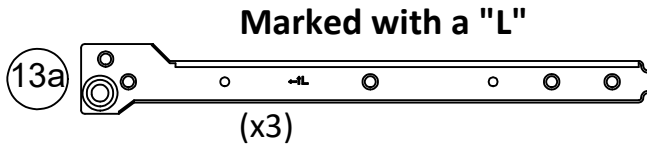
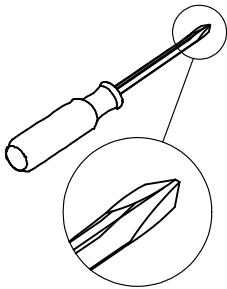

# STEP 3

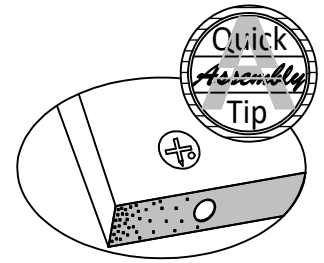
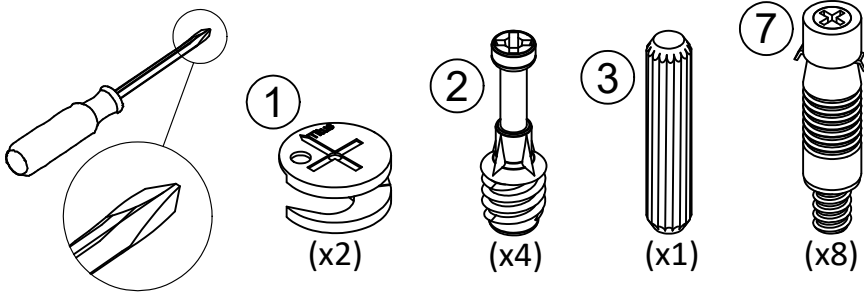

Proper orientation of CAM LOCK

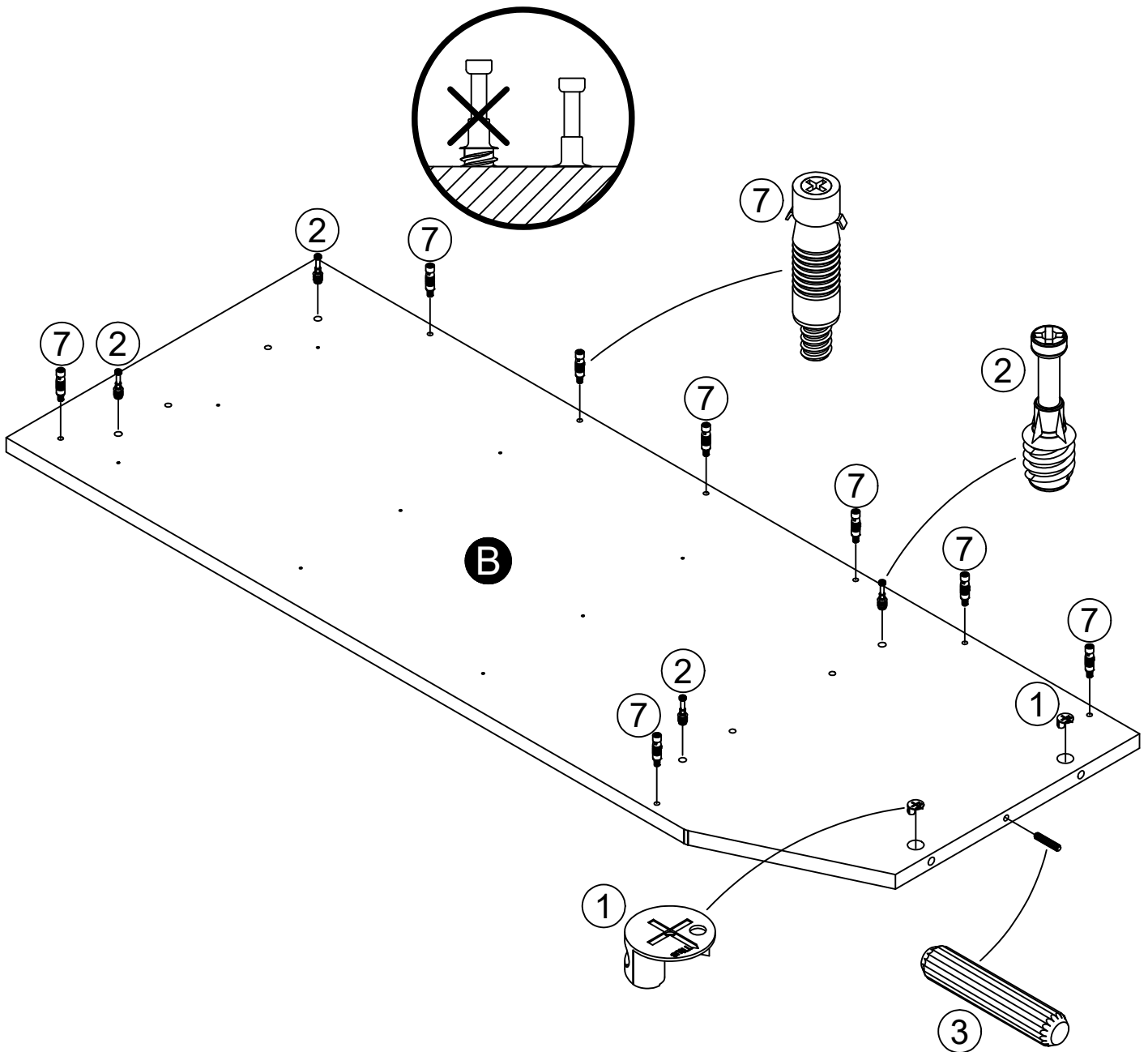

# STEP 4

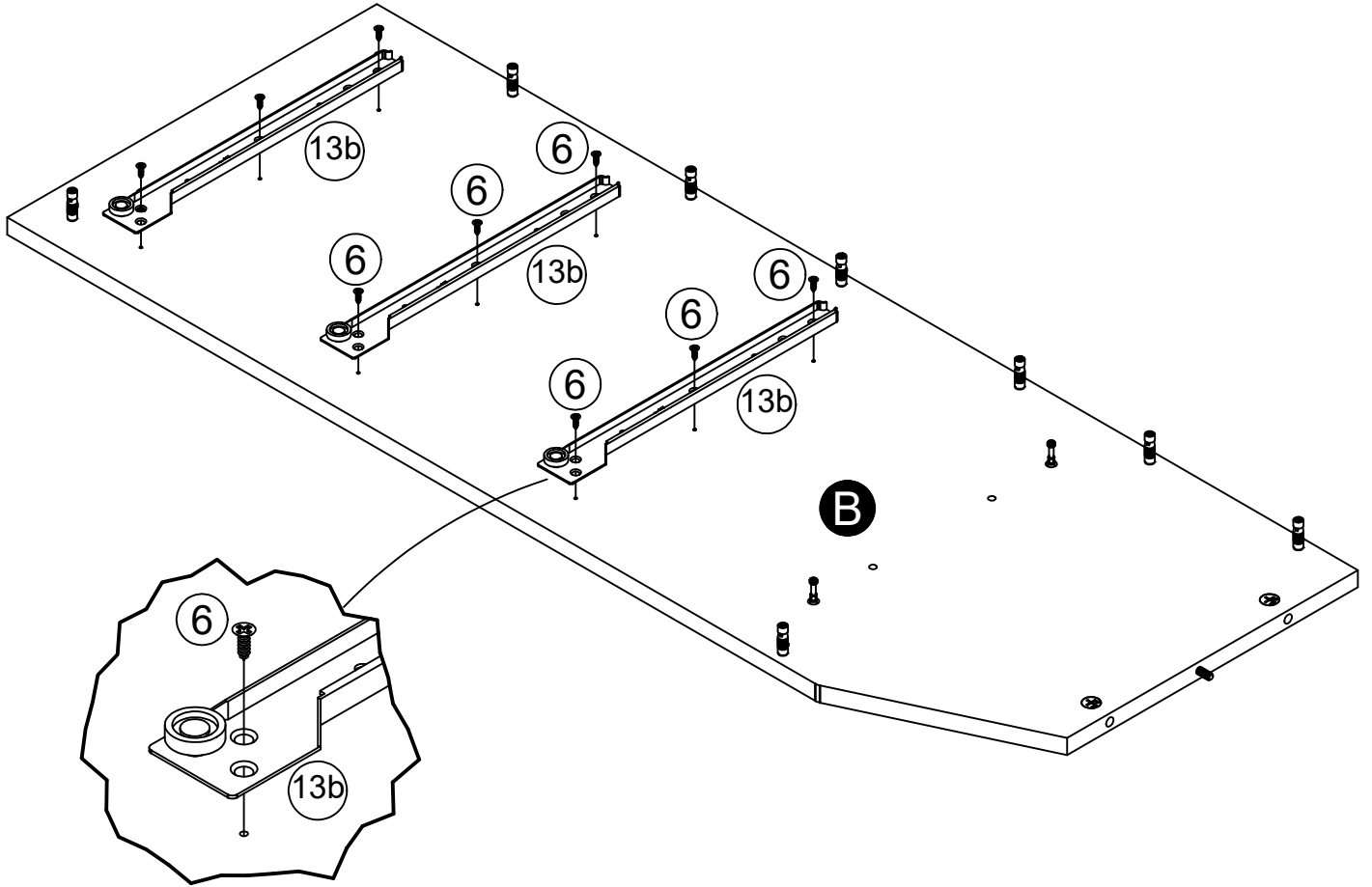
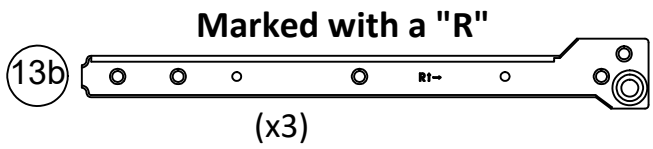
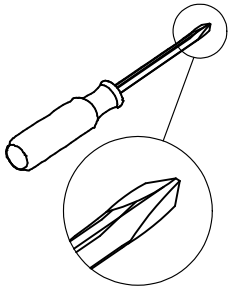

# STEP 5

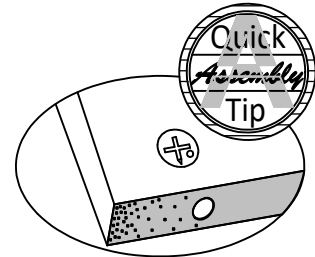
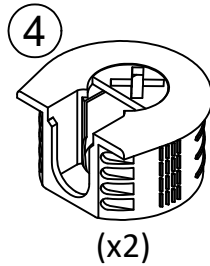
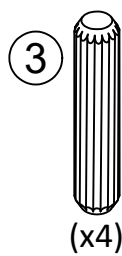
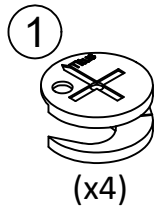
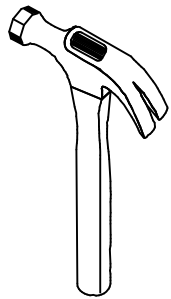

Proper orientation of CAM LOCK

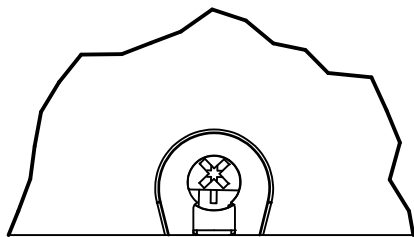
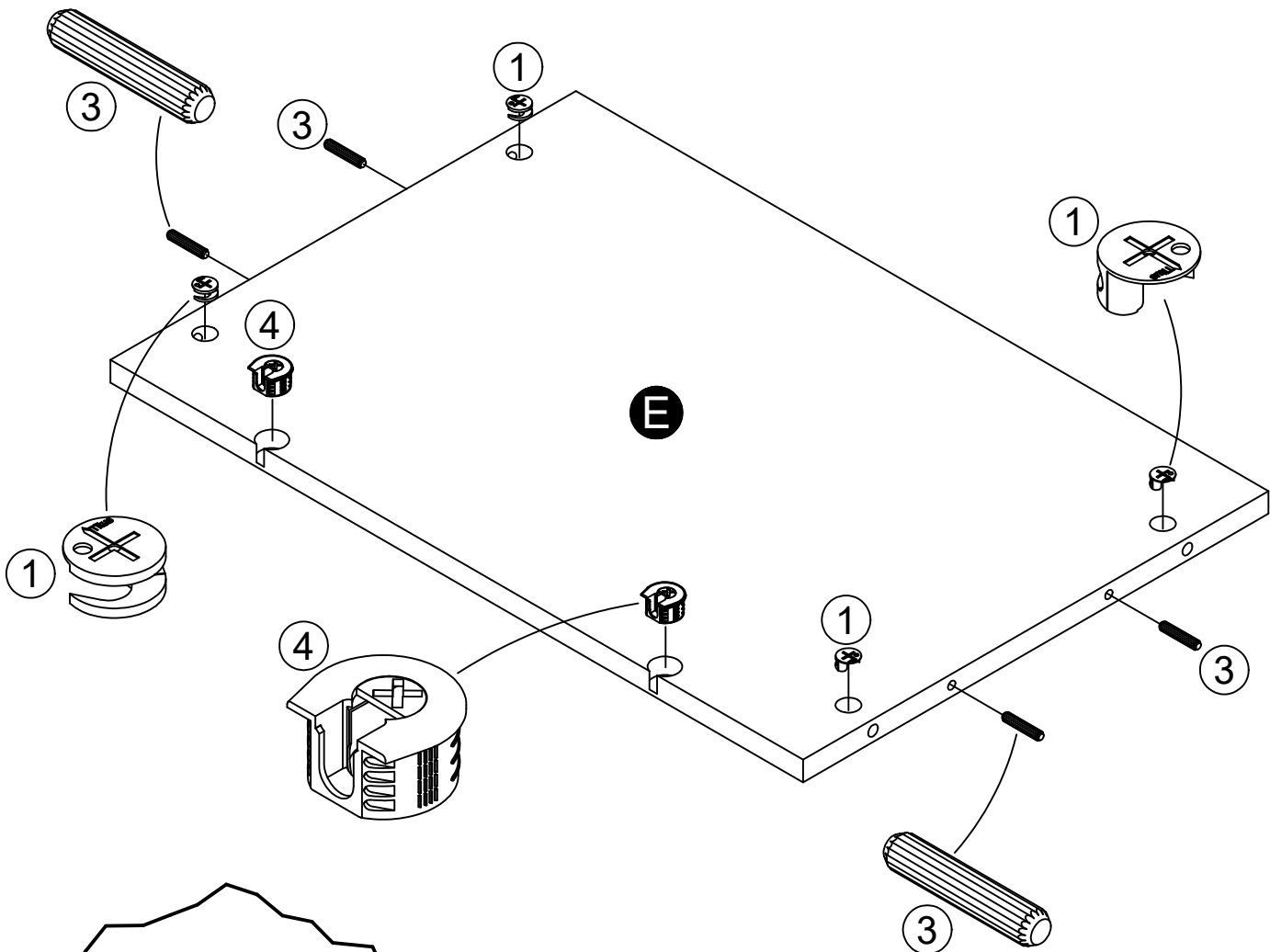

Be sure connector (4) is positioned as shown before inserting into hole. Tap with a hammer to fully insert.

# STEP 6

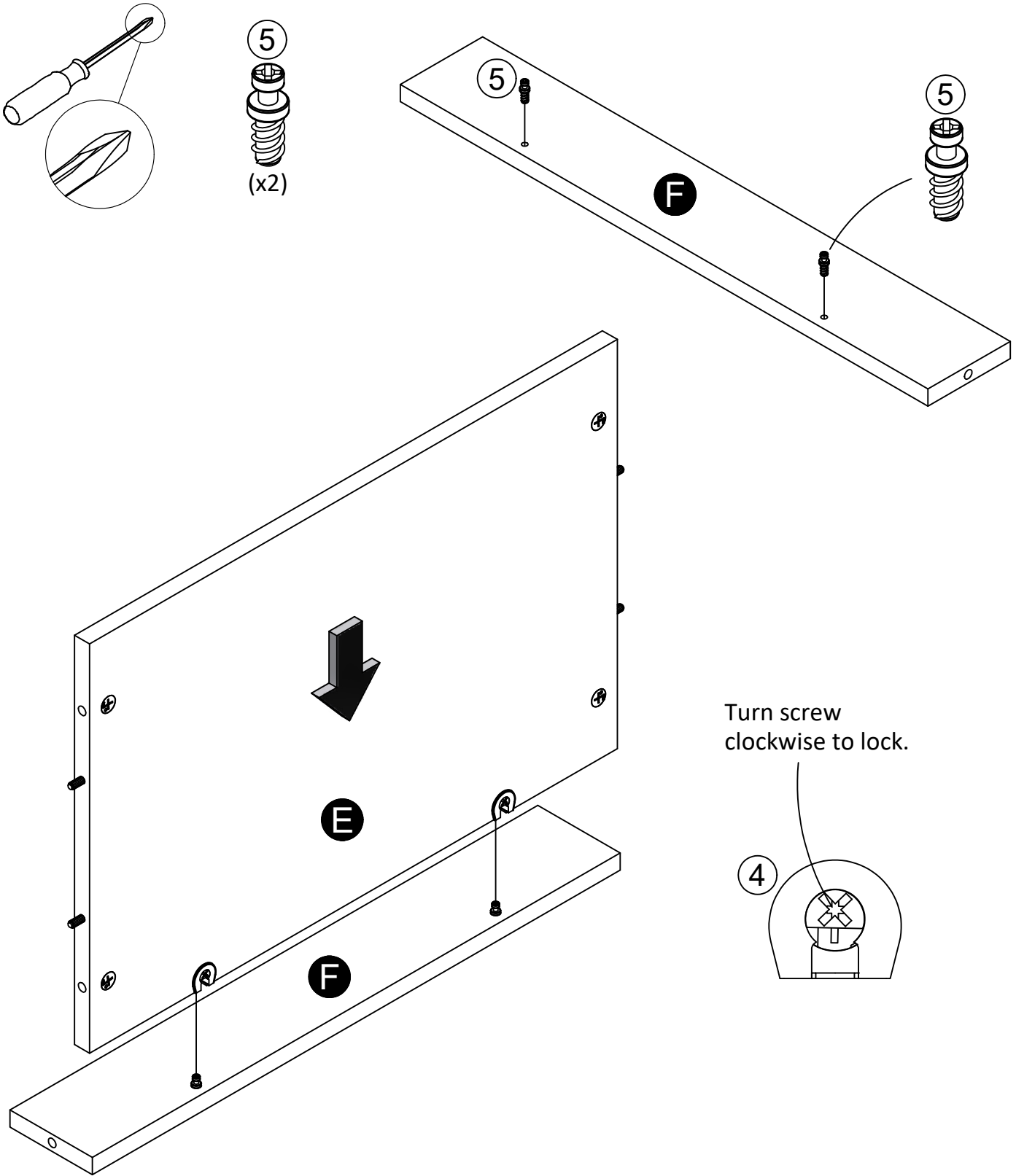

# STEP 7

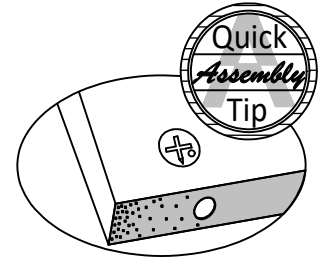
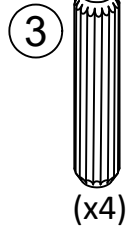
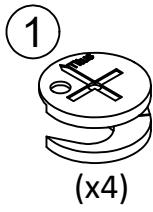
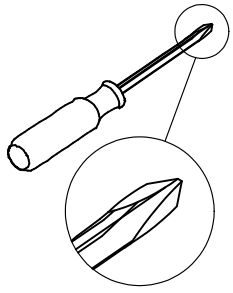

Proper orientation of CAM LOCK

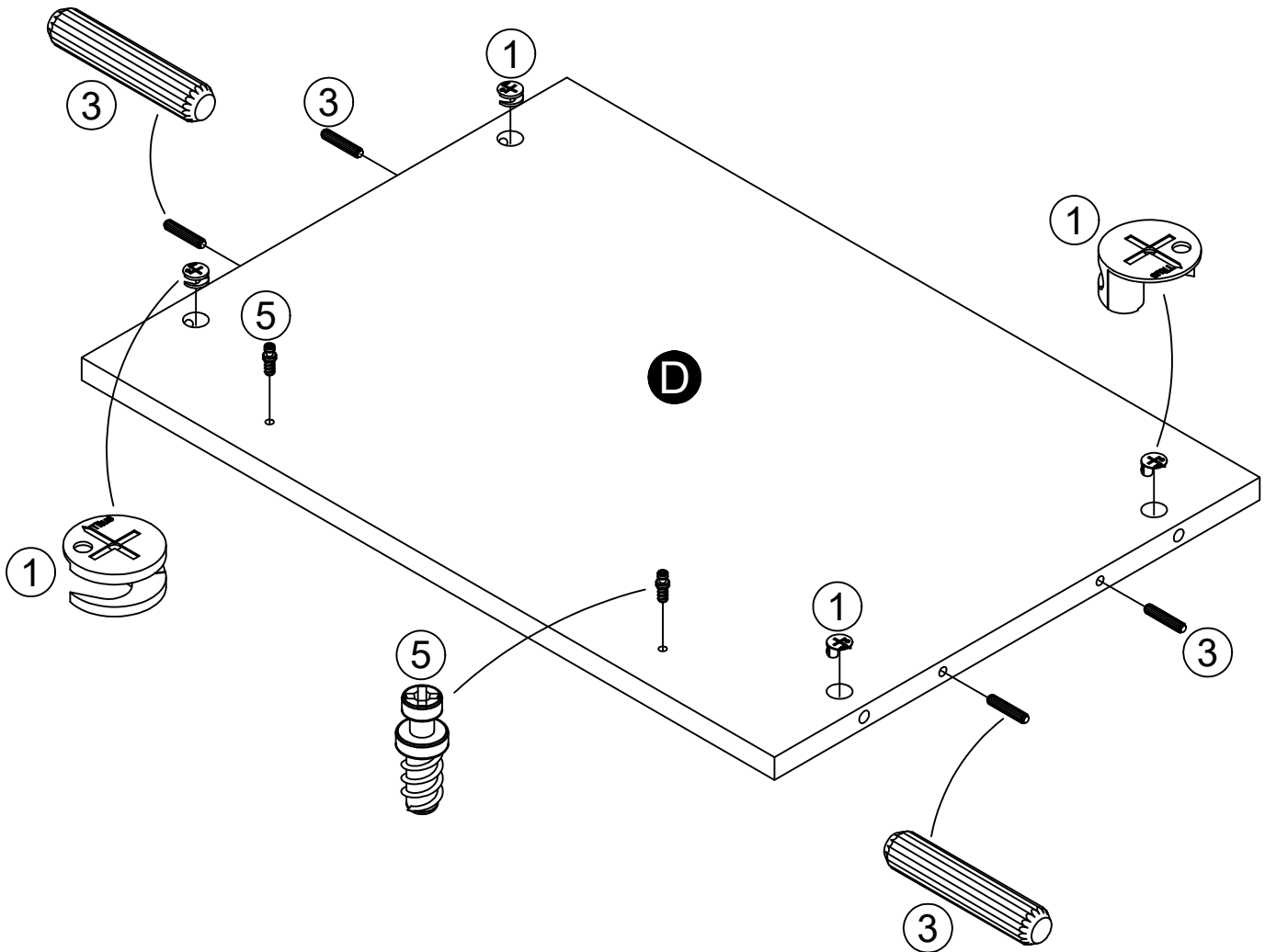

## STEP 8

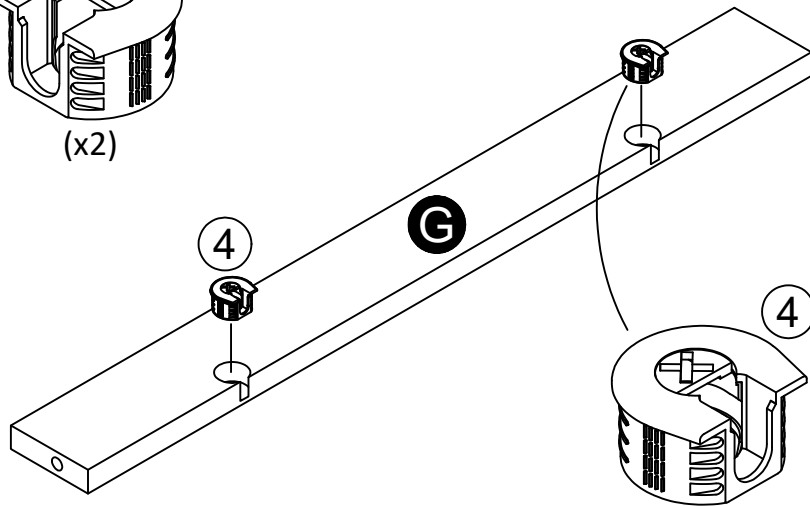
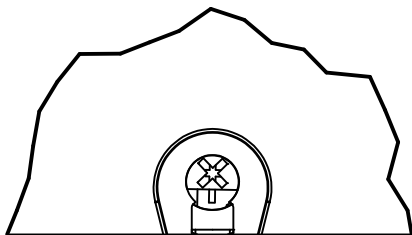
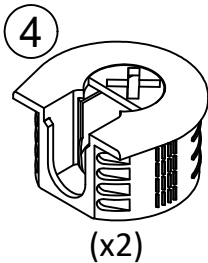
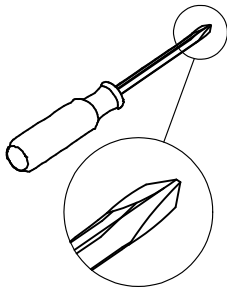

Be sure connector (4) is positioned as shown before inserting into hole. Tap with a hammer to fully insert.

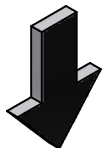

Turn screw clockwise to lock.

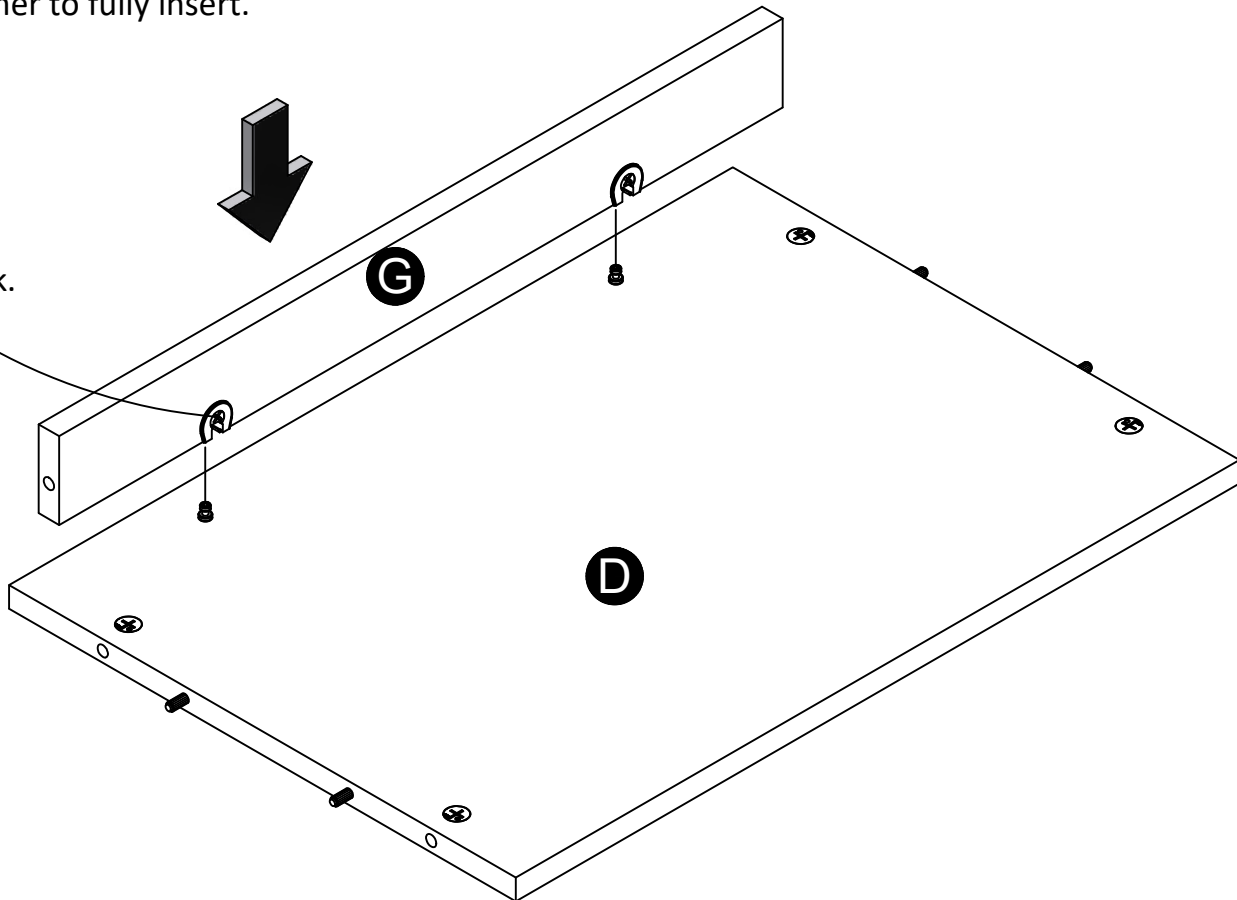



# STEP 9

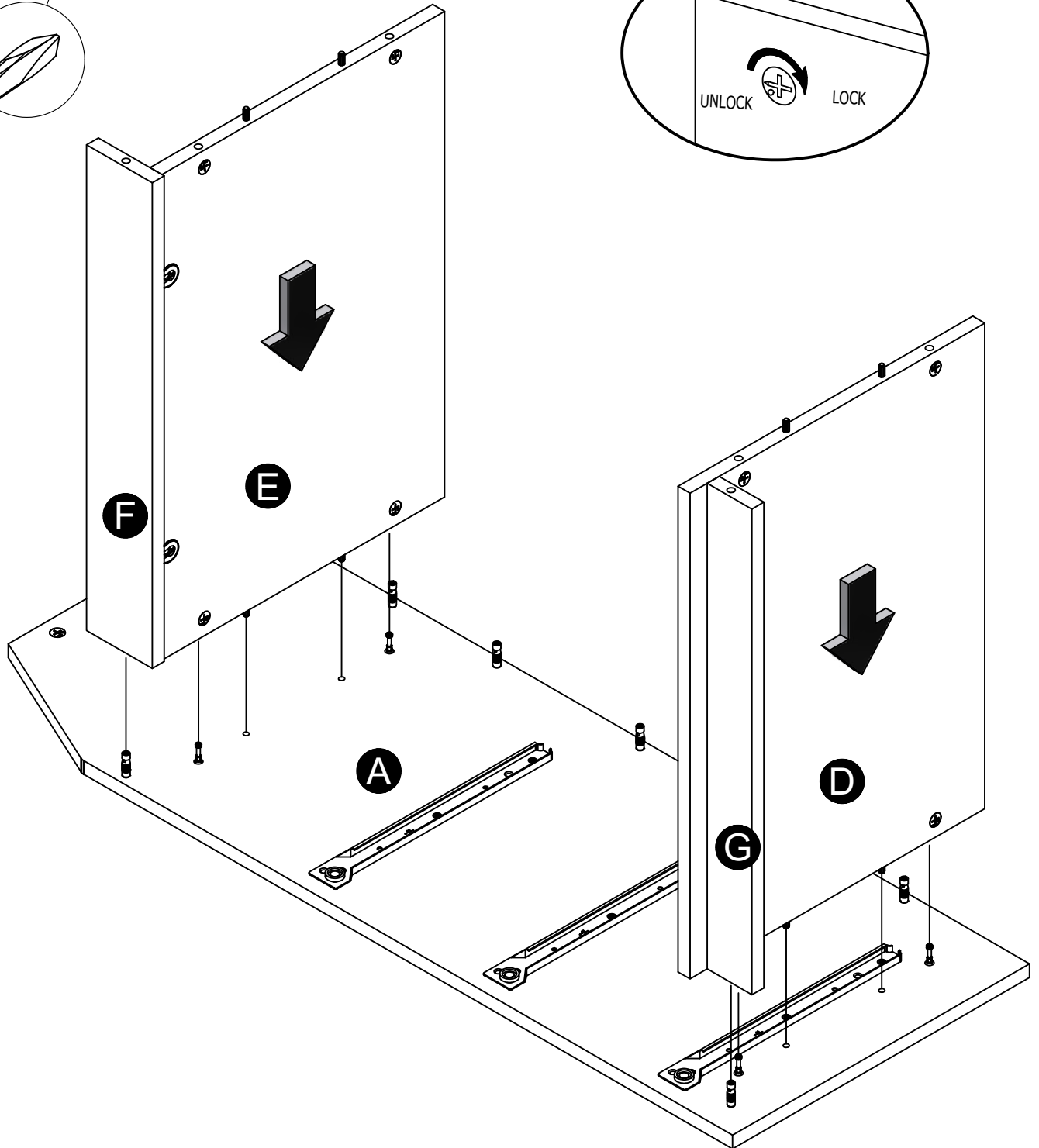
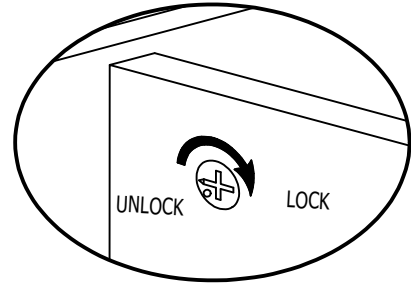
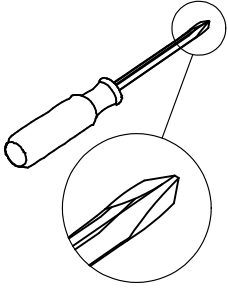

# STEP 10

Note:  
Hole to the top and on back side.

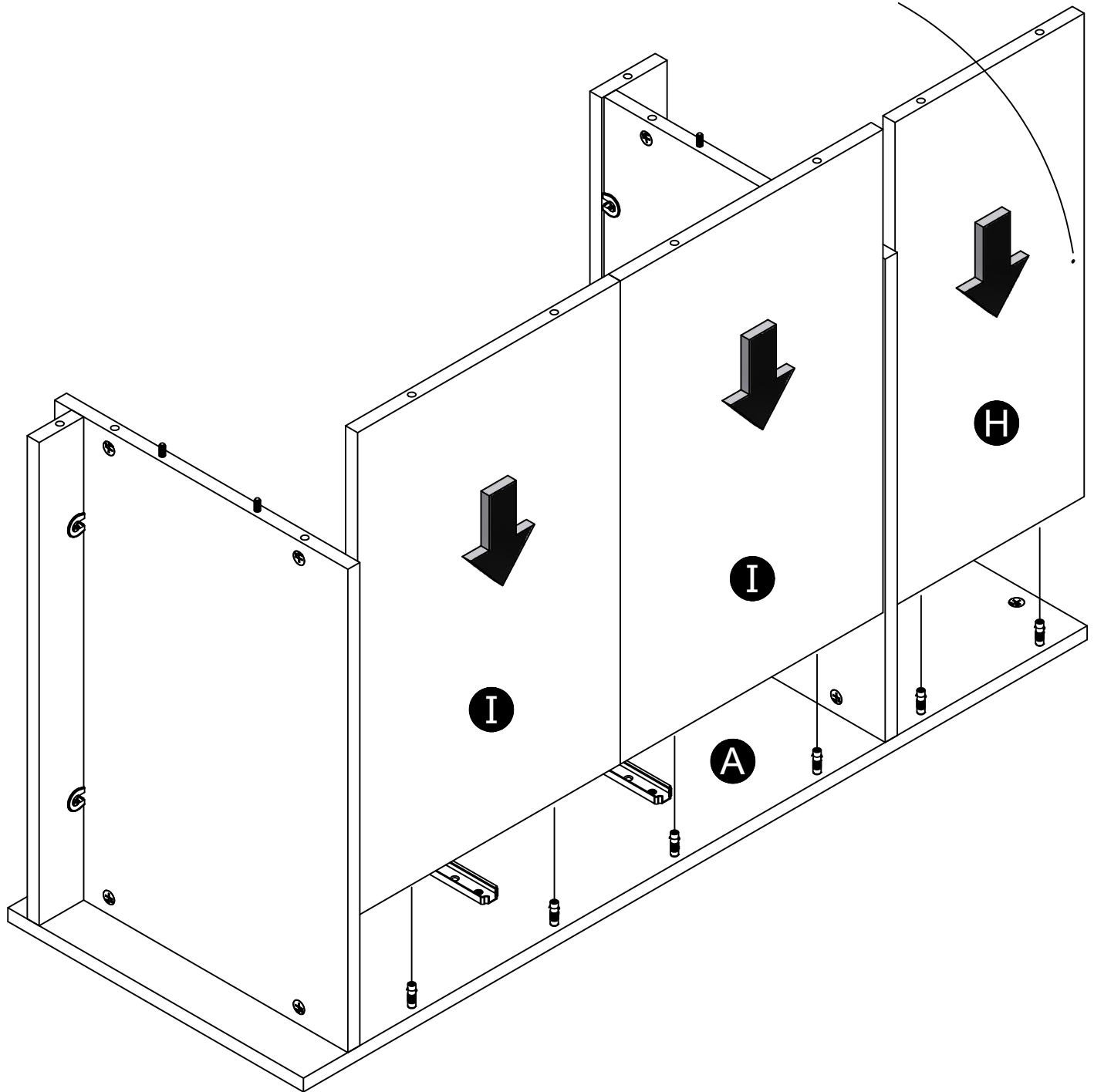

## STEP 11

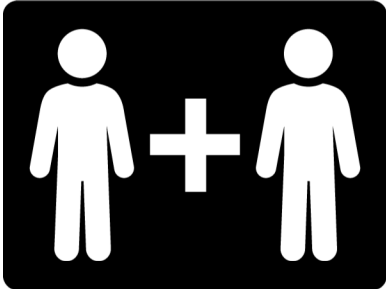
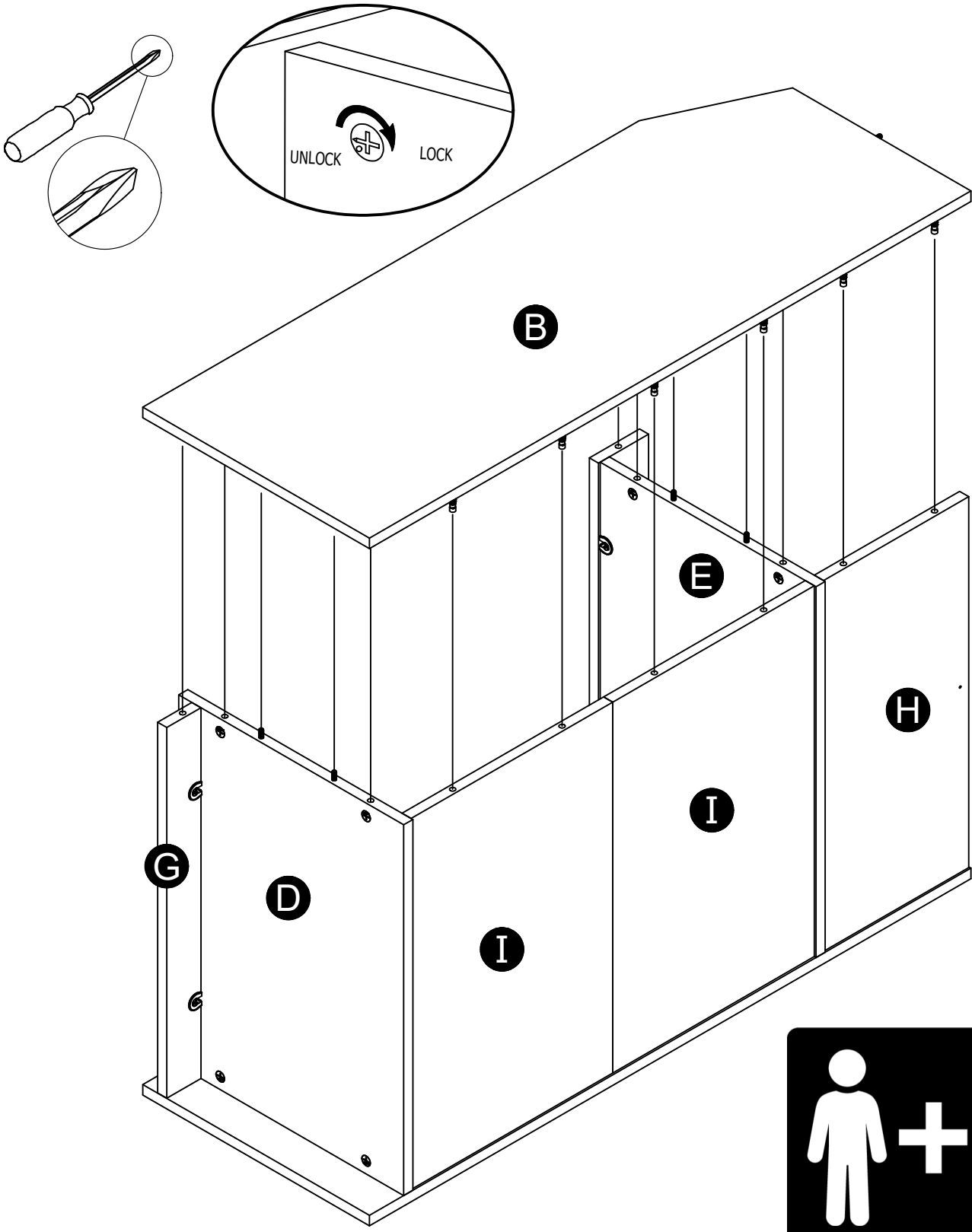

# STEP 12

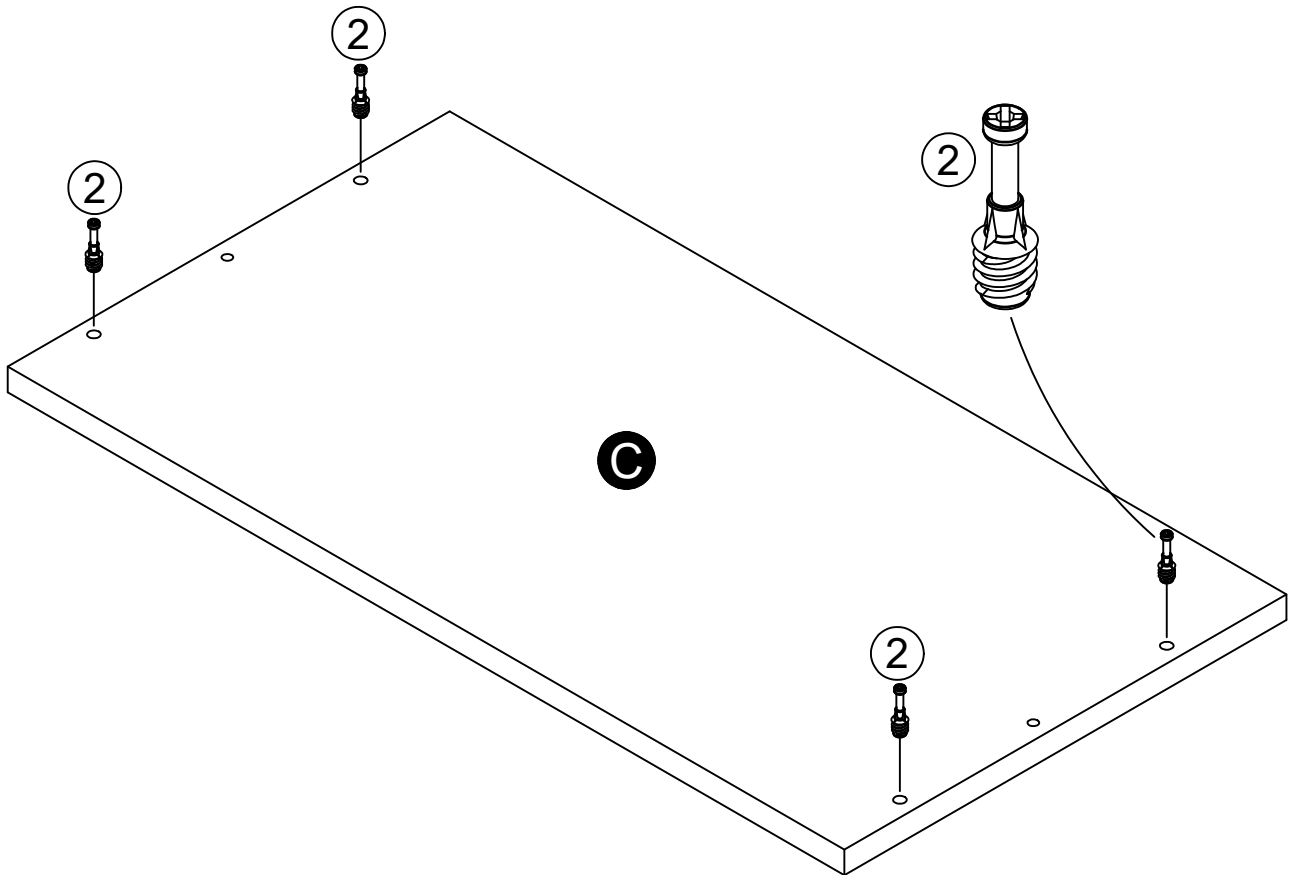
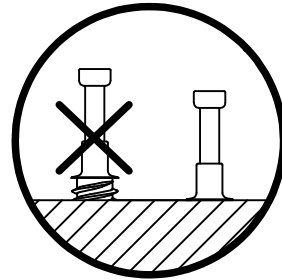
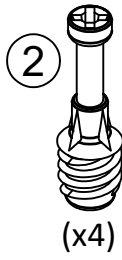
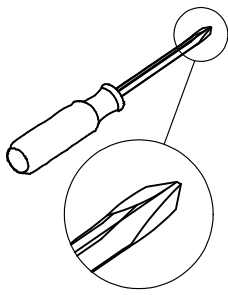

# STEP 13

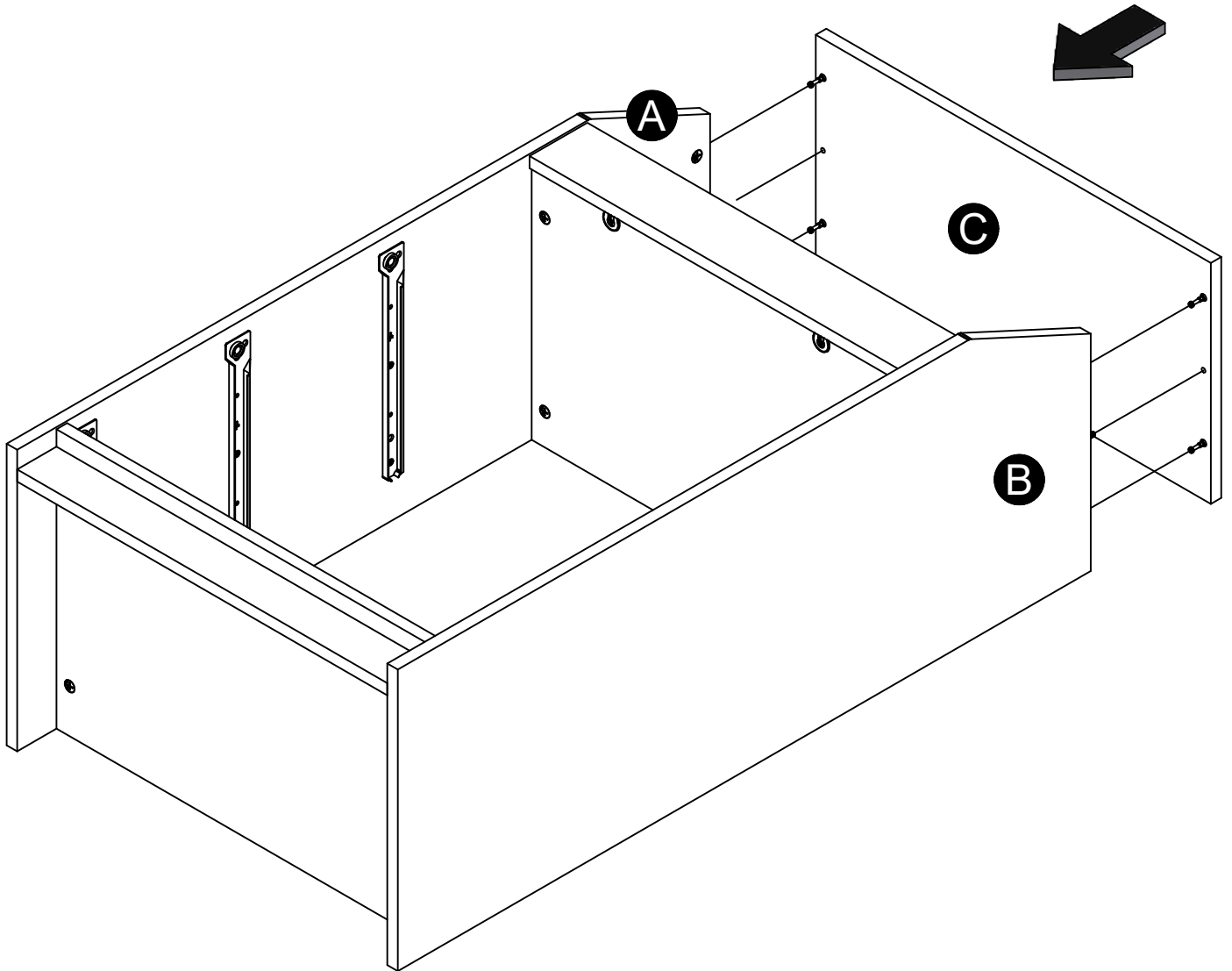
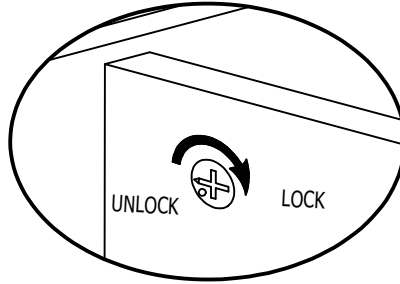
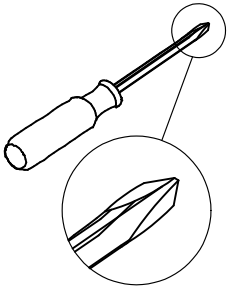

**STEP 14**

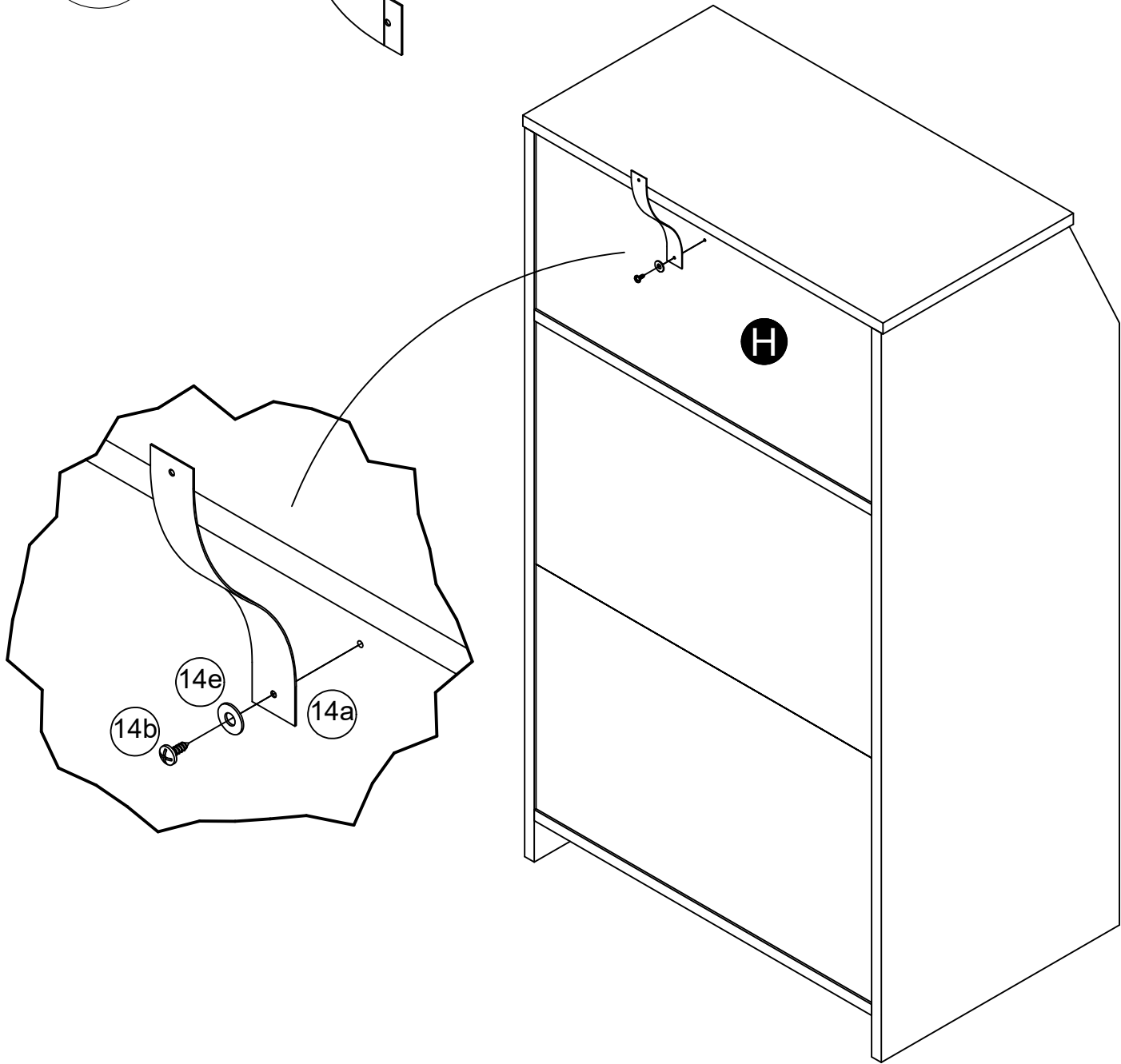
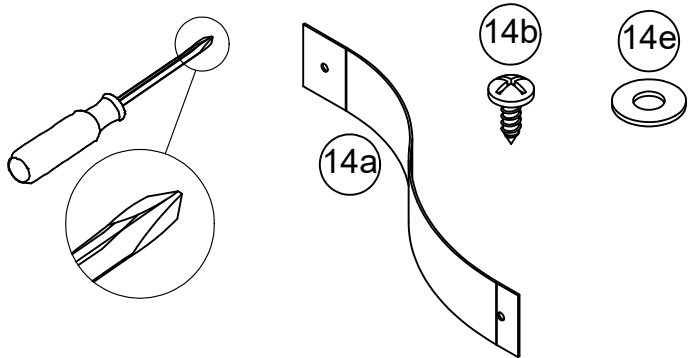

## STEP 15

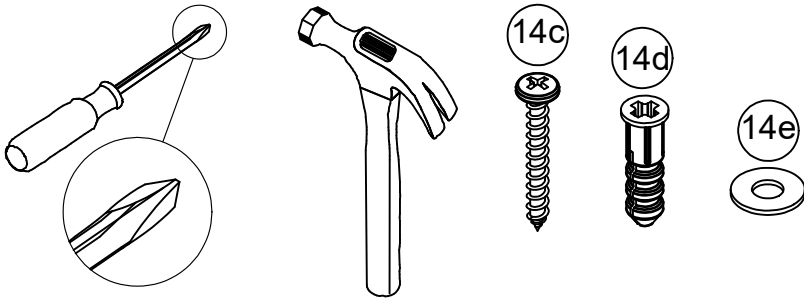

**For Masonry, Concrete, or other wall materials:**

Consult your local hardware store for appropriate anchors to securely attach the safety bracket.

**IMPORTANT:** THIS UNIT MUST BE SECURE TO THE WALL TO HELP PREVENT TIPOVER. FOLLOW THESE INSTRUCTIONS TO INSTALL THE ANTI-TIPPING SAFETY BRACKET PROVIDED WITH THIS PRODUCT.

**WARNING**

**Serious or fatal crushing injuries can occur from furniture tipover.**

**To prevent tipover:**

- \* Install tipover restraint provided
- \* Place heaviest items in the lowest drawers
- \* Unless specifically designed to accommodate, do not set TVs or other heavy objects on the top of this product
- \* Never allow children to climb or hang on drawers, door, or shelves
- \* Never open more than one drawer at a time

**Use of tipover restraints may only reduce, but not eliminate the risk of tipover**

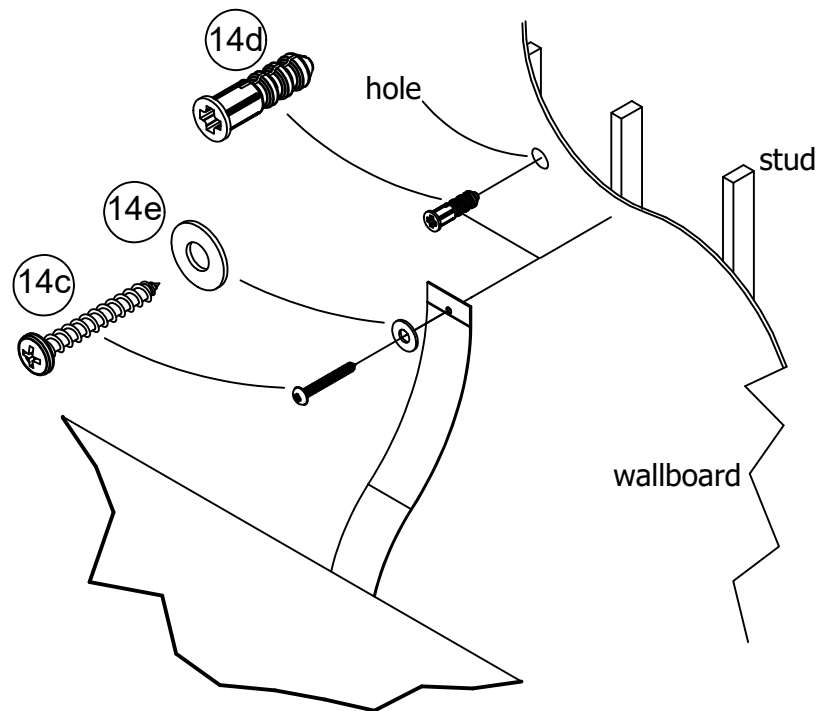

**OPTION 1: Attachment into a wall stud (preferred method)**

Using a stud finder, locate a stud in the wall. Place your unit against the wall, with the safety bracket aligned in this location. To make driving the screw easier, you can drill a 1/8" diameter pilot hole (3mm) through the safety bracket into the stud. Drive the screw through the safety bracket into the wall stud.

**OPTION 2: Attachment into drywall**

Locate your unit where desired against a wall and mark the wall through the safety bracket, then move your unit aside. Drill a 3/16" diameter hole (5mm) into the wallboard. Tap the wall anchor into the hole until it is flush. Move your unit into location and fasten the wall bracket to the wall anchor with the screw.

## STEP 16

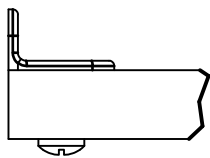
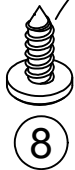
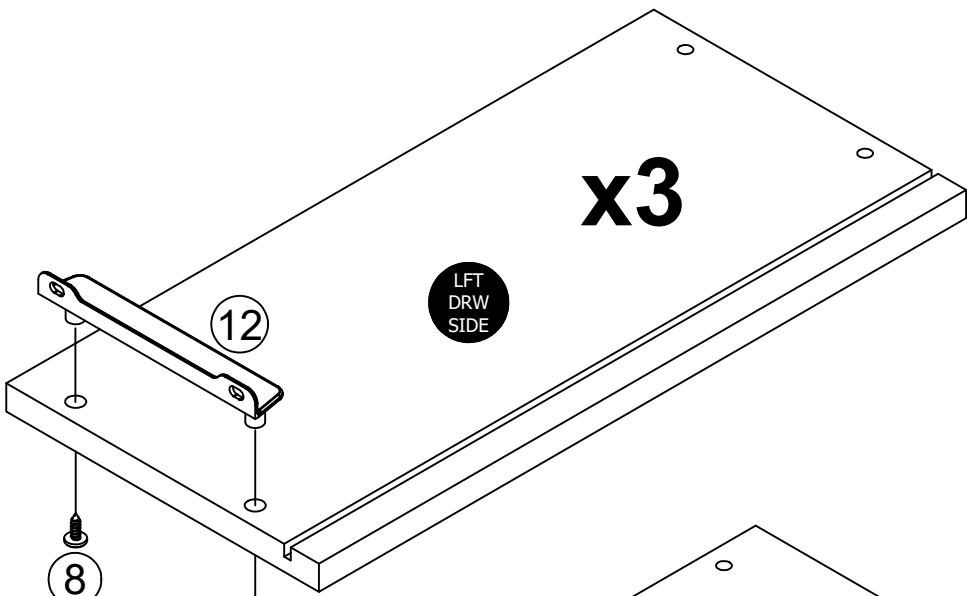
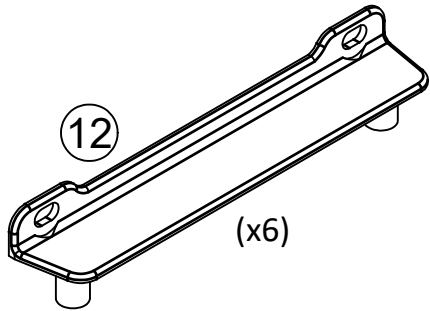
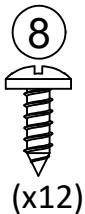
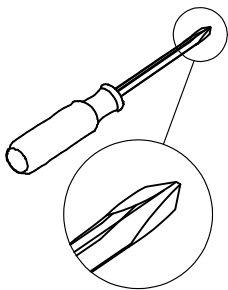

side view

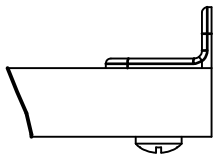
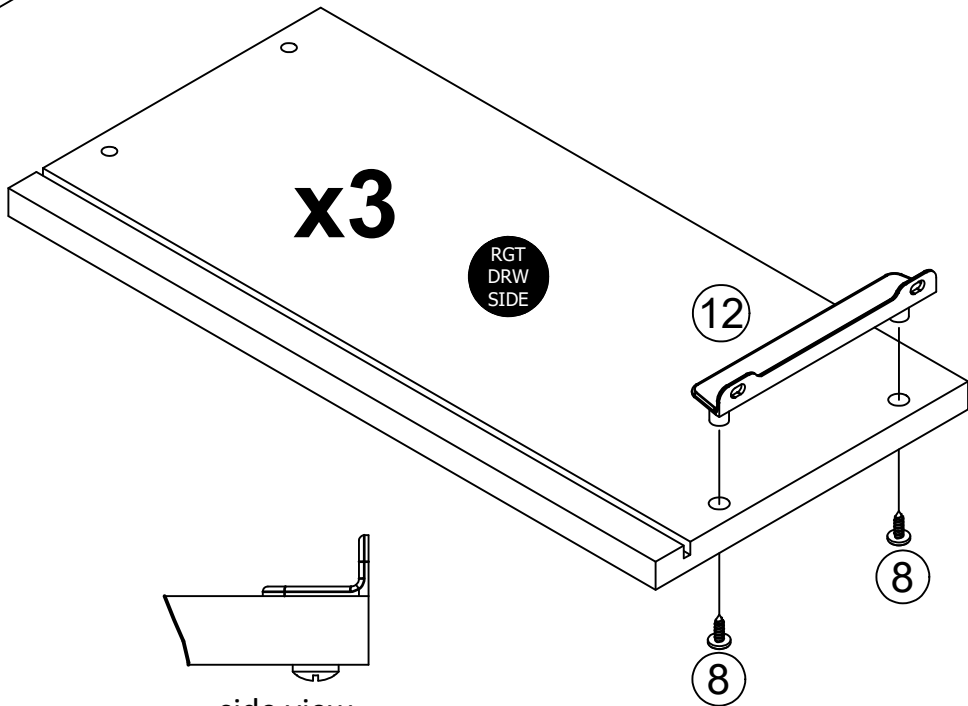

side view



# STEP 17

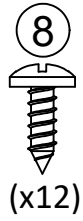
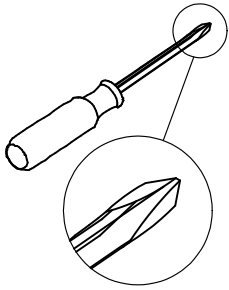

Be sure the groove in the drawer sides are centered with groove in drawer front.

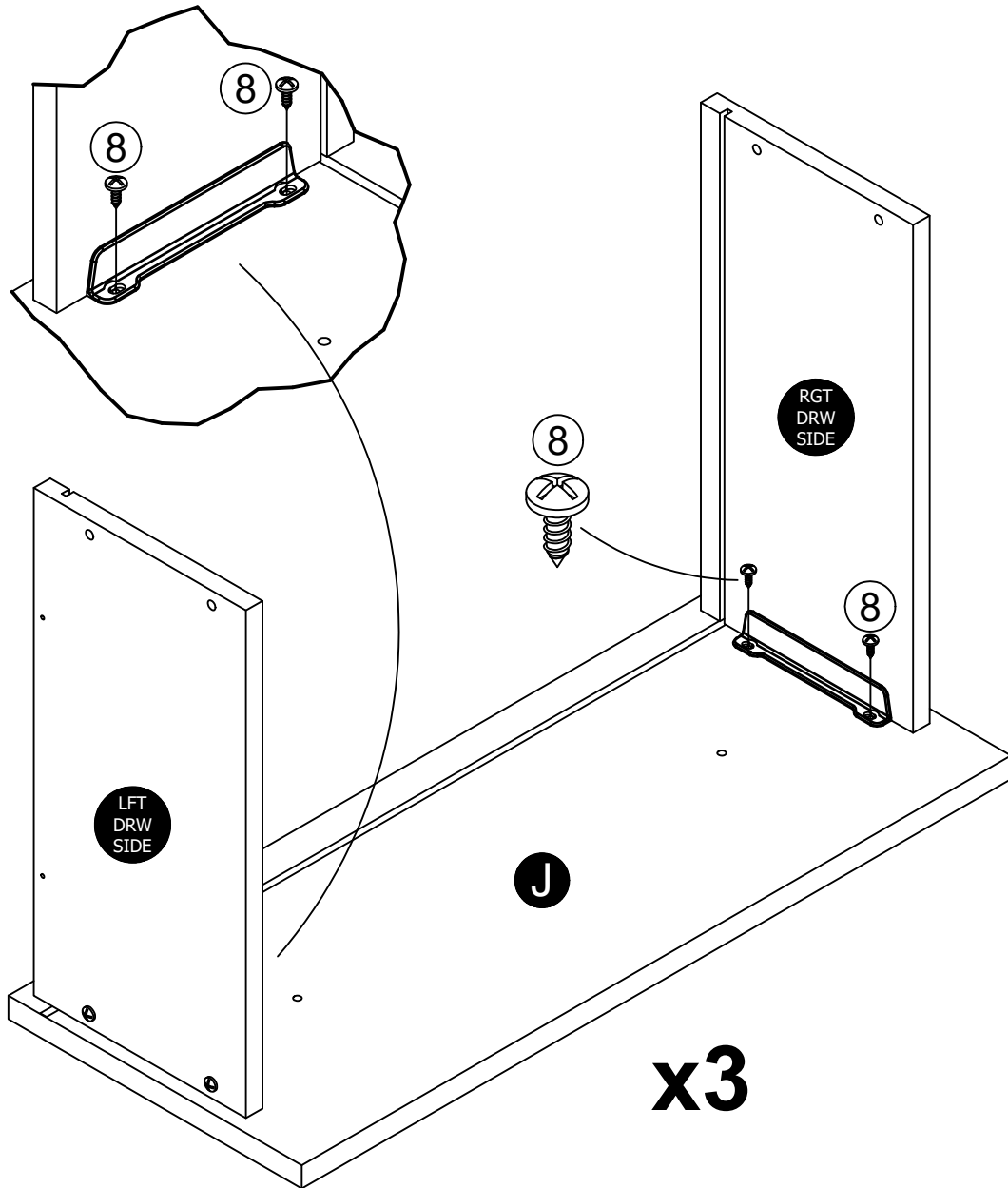

# STEP 18

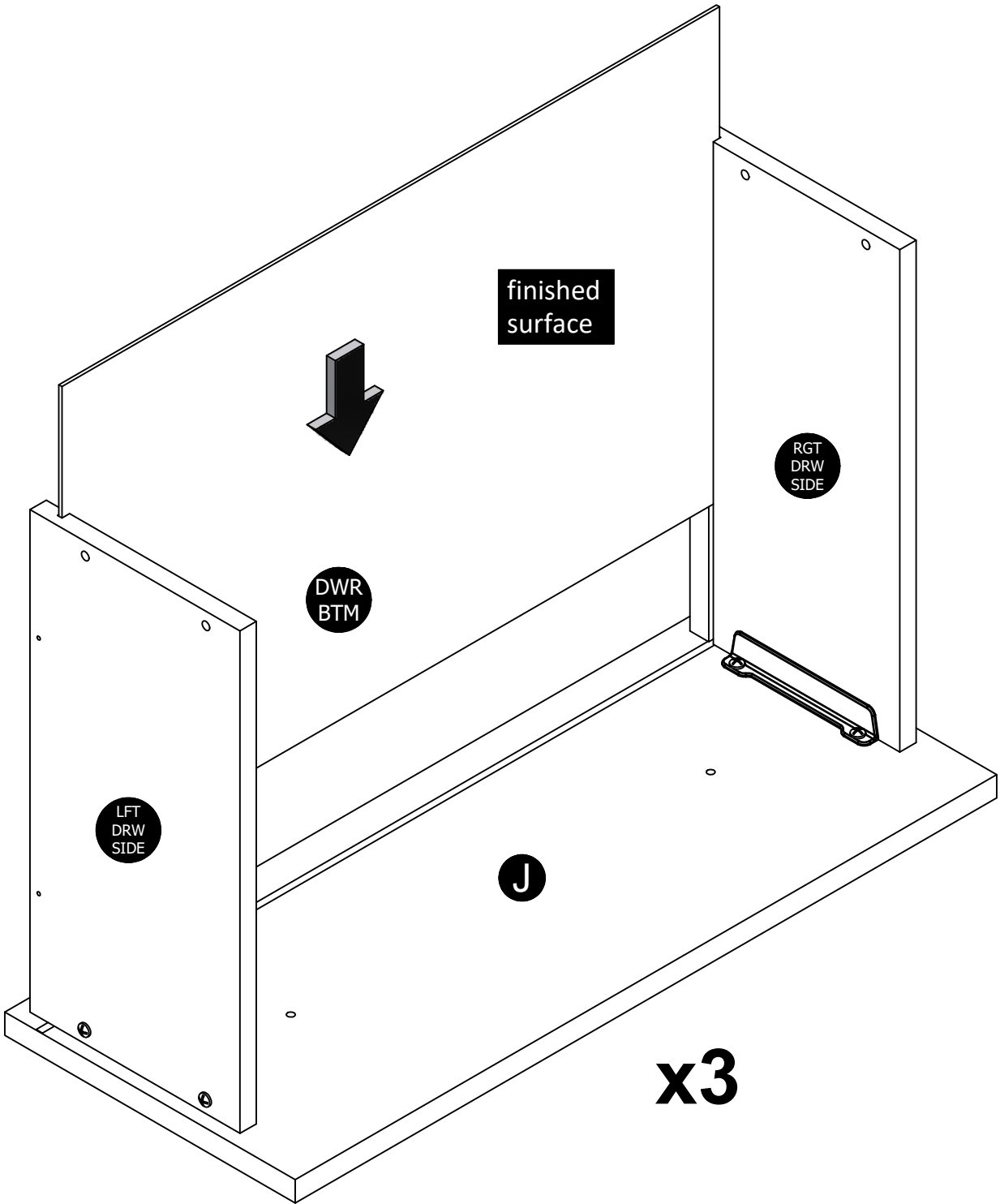

# STEP 19

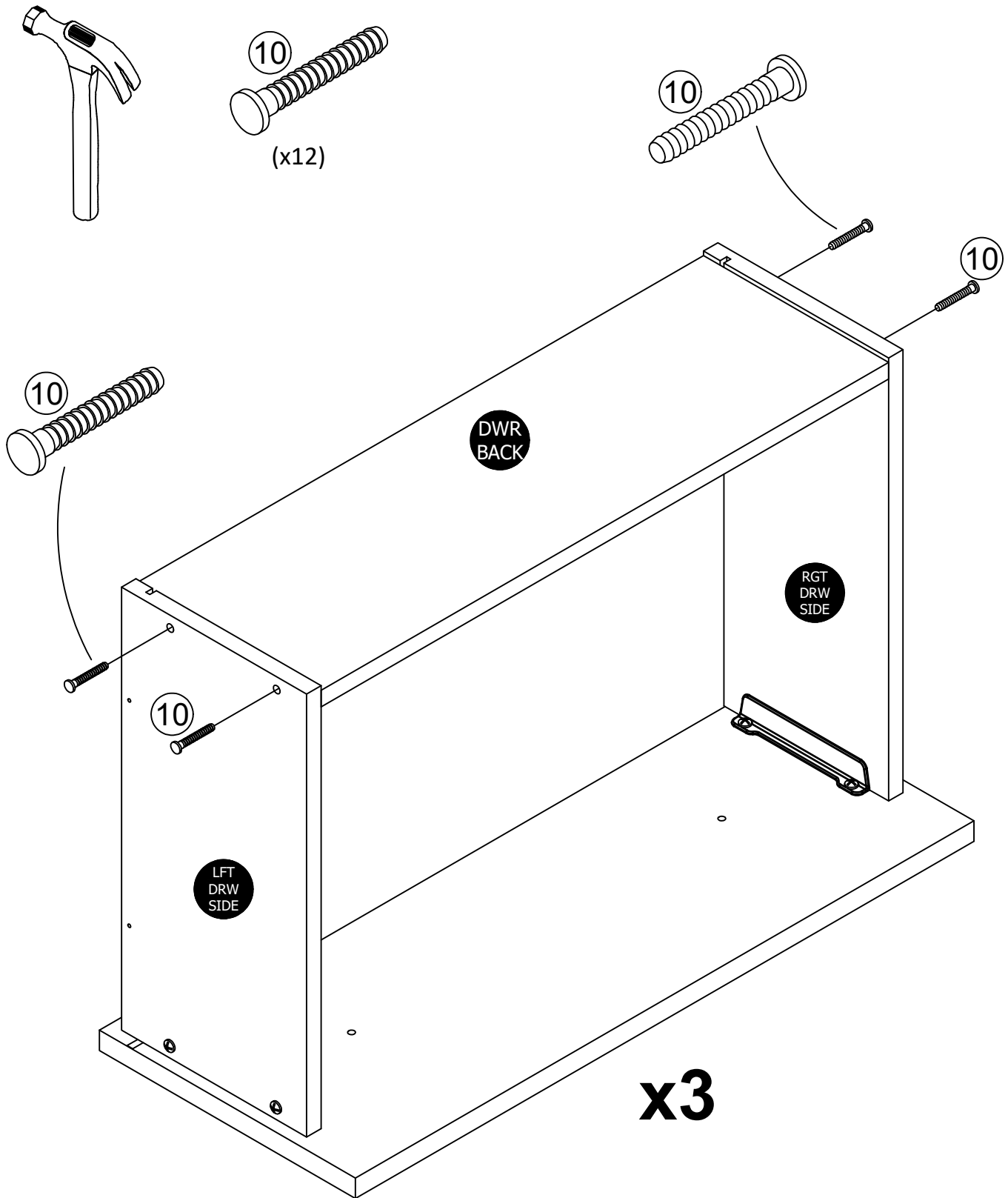

## STEP 20

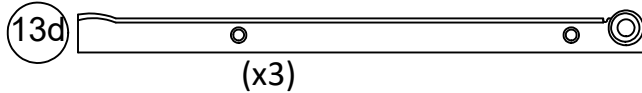
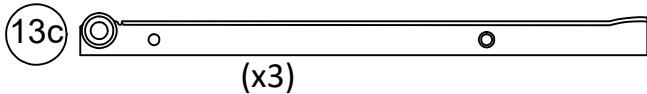
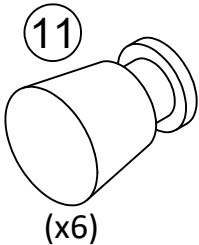
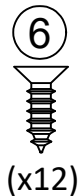
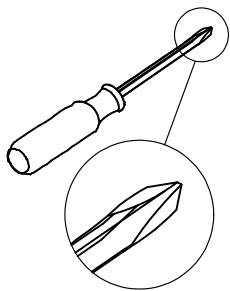

Attach the slides first and then the knobs.

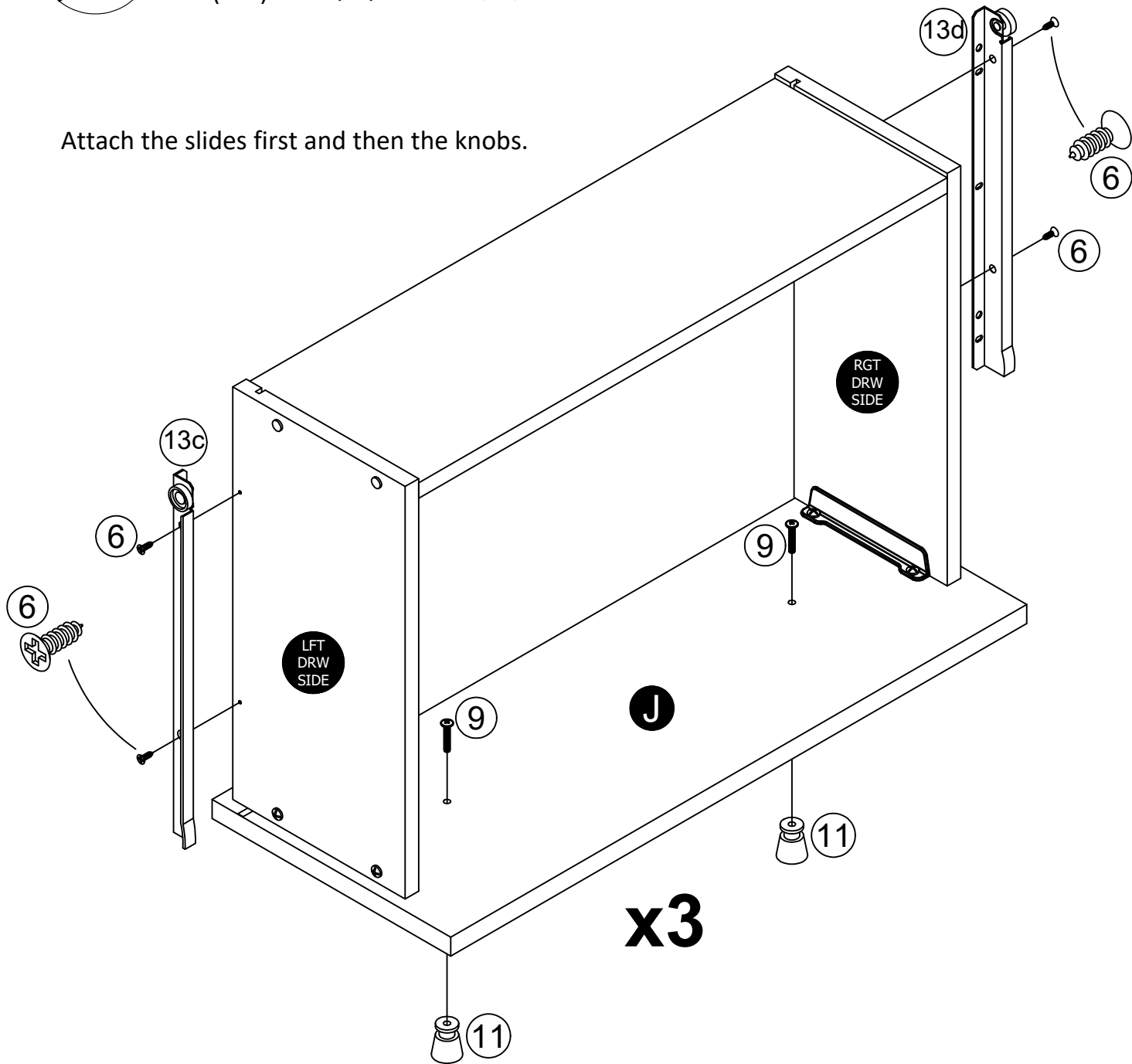

# STEP 21

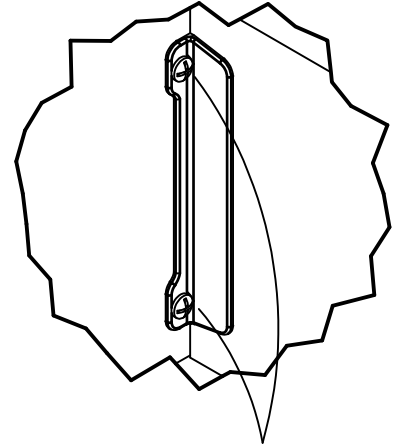

Note: The drawer bracket holes are slotted. Drawer fronts can be adjusted by loosening screws, making needed adjustments and retightening screws.

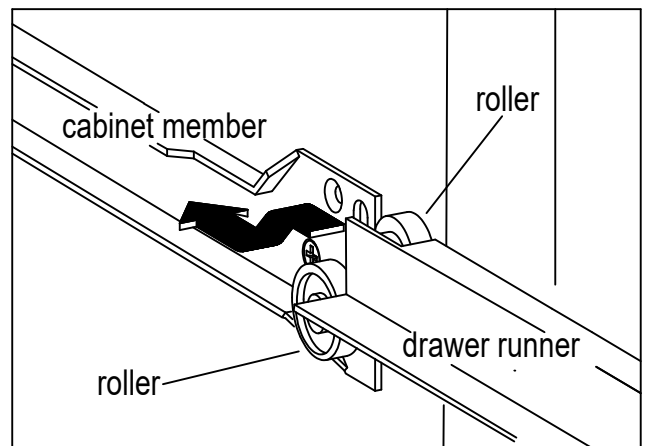
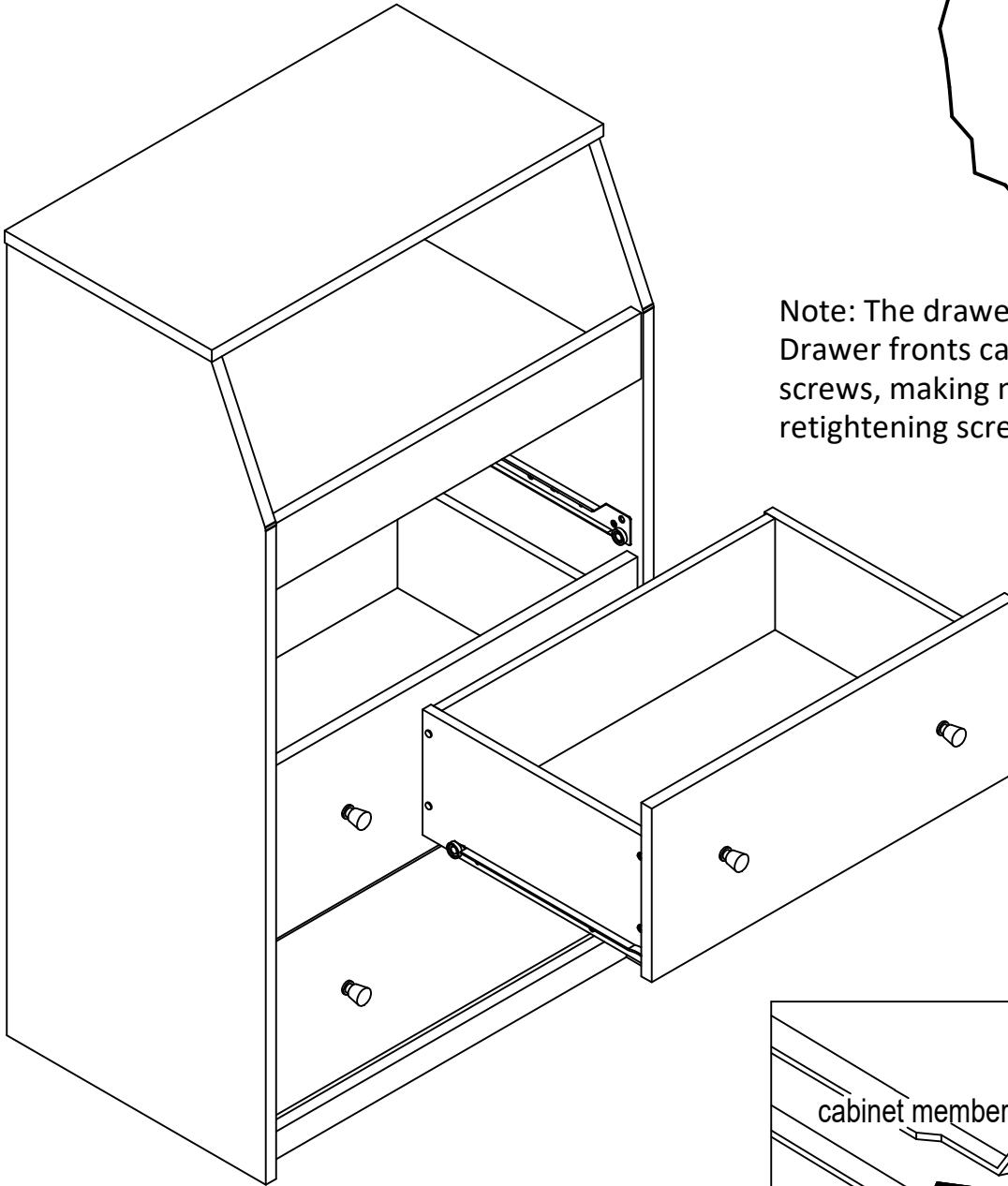

## Maximum Loads

This unit has been designed to support the maximum loads shown. Exceeding these load limits could cause sagging, instability, product collapse, and/or serious injury.

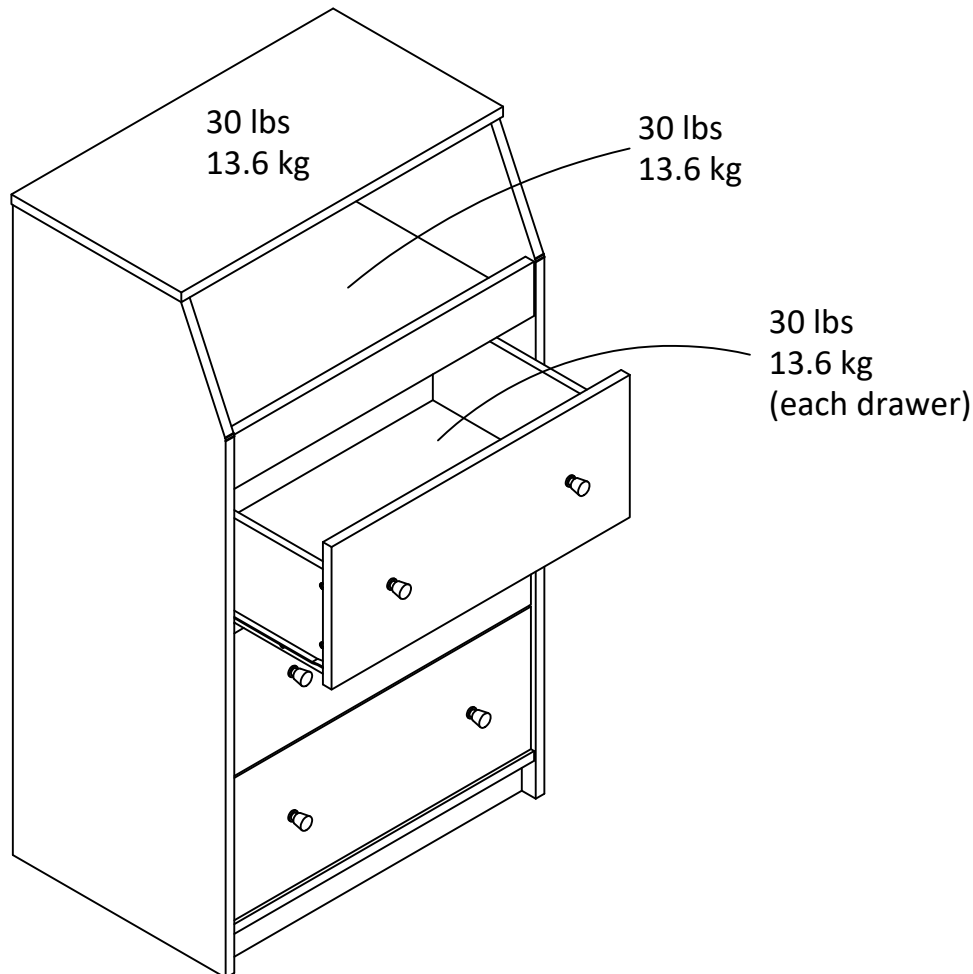

**Warning: Risk of injury to persons - do not place a television on this furniture. This furniture is not approved for use with a television.**

### Certificate of Conformity

1. This certificate applies to the Dorel Home Furnishings, Inc. product identified by this instruction manual.
2. This certificate applies to compliance of this product with the CPSC Ban on Lead-Containing Paint (16 CFR 1303).
3. This product is distributed by: Dorel Home Furnishings, Inc.  
410 East First Street South  
Wright City, MO 63390  
636-745-3351
4. Site of Manufacture: Tiffin OH
5. See front page of instruction manual for date of manufacture.

---

## Register your product to receive the following:



- \* New trend details - sneak peek on what's new
- \* Surveys - have a voice within our community
- \* Exclusive deals and discount codes
- \* Quick and easy replacement part service

To register your product, visit [ameriwoodhome.com](http://ameriwoodhome.com)

## *5 Star Rating*



Visit your local retailer's website, rate your purchased product and leave us some feedback!

We would like to extend a big "Thank You" to all of our customers for taking the time to assemble this Ameriwood Home product, and to give us your valuable feedback.

*Thank  
You!*

## Cubierta Delantera

Este libro de instrucciones contiene información **IMPORTANTE** de seguridad. Por favor lea y manténgalo para referencia en el futuro.

**No Regrese este producto!** Comuníquese con nuestro amigoso equipo de servicio al cliente para obtener ayuda.

Llámenos al: 1-800-489-3351 (Gratis) Lunes - Viernes 9am - 5pm CST

Visitar: [www.ameriwoodhome.com](http://www.ameriwoodhome.com)

## PRECAUCION

Este mueble puede volcarse y causar graves heridas y/o muerte.

Anclar el mueble a un poste de madera en la pared (si esto se requiere).

No Permita que los niños monten el mueble.

Mantenga los artículos más pesados en los cajones de abajo.

## Consejos Útiles (página 2)

- Abra su artículo en el área donde usted planea utilizarlo para evitar levantar y moverlo menos
- Identificar, ordenar y contar las piezas antes de intentar ensamblar
- Las clavijas de compresión se golpean con un martillo
- Las diapositivas están marcadas con una R (derecha) y L (izquierda) para la colocación correcta
- Asegúrese de que siempre este el punto localizado en la parte superior de bloqueador de leva este volteado hacia borde exterior
- Utilizar todos los clavos para el panel de atrás y distribuirlos por igual
- El panel de atrás debe utilizarse para asegurarse de que la unidad quede fija y firme
- No use químicas fuertes ni limpiadores abrasivos en este artículo
- Nunca empuje, tire ni arrastre los muebles

## Antes de Que Empieces (página 3)

- Lea cuidadosamente cada paso y siga el orden correcto
- Separar y contar todas sus piezas y hardware
- Dése suficiente espacio para el proceso de ensamble
- Tenga las siguientes herramientas: destornillador de cabeza plana, #2 cabeza Phillips  
Destornillador y martillo
- Precaución: Si usa un taladro electrónico o un destornillador eléctrico para atornillar, por favor asegúrese que deje de atornillar cuando el tornillo este apretado. Fallar hacer esto puede causar barrer el tornillo.

## Sistema de fijar el bloqueo de leva (página 3)

Esta sistema de fijar el bloqueo de leva sera usado en todo el proceso ensamble.



## Página 13 / 16

Asegúrese de que el conector (4) esté posicionado como se muestra antes de insertarlo en el agujero. Golpee con un martillo para que se inserte por completo.

## Página 18

Nota:

Agujero en las partes de arriba y posterior.

## Página 23

### **Para mampostería, concreto u otros materiales de pared:**

Consulte con su ferretería local respecto a los anclajes apropiados para fijar correctamente el soporte de seguridad.

**IMPORTANTE:** ESTA UNIDAD SE DEBE ASEGURAR A LA PARED PARA AYUDAR A PREVENIR VOLCAMIENTOS. SIGA ESTAS INSTRUCCIONES PARA INSTALAR EL SOPORTE DE SEGURIDAD ANTIVOLCAMIENTOS PROVISTO CON ESTE PRODUCTO.

### **ADVERTENCIA**

**El volcamiento de este mueble puede causar lesiones graves o fatales por aplastamiento.**

### **Para prevenir volcamientos:**

- \* Instale el protector volcamiento proporcionado
- \* Coloque los objetos mas pesados en las gavetas mas bajas
- \* No coloque televisores ni otros objetos pesados sobre este producto, a menos que estén específicamente diseñados para acomodarse al mismo
- \* Nunca permita que los niños se trepen o cuelguen de las gavetas, puertas o repisas
- \* Nunca abra mas de una gaveta a la vez

**El uso de los protectores antivolcamiento solo puede reducir, pero nunca eliminar del todo, el riesgo de un volcamiento**

### **OPCIÓN 1: Fijación a montante (método preferido)**

Con ayuda de un detector de vigas, ubique un montante en la pared. Coloque su unidad contra la pared, con el soporte de seguridad alineado en esta ubicación. Para facilitar la colocación del tornillo, puede taladrar un agujero piloto de 1/8" (3 mm) de diámetro a través del soporte de seguridad en el montante. Inserte el tornillo a través del soporte de seguridad y dentro del montante.

### **OPCIÓN 2: Fijación al drywall o yeso**

Coloque su unidad donde lo desee y contra la pared, marque la pared a través del soporte de seguridad y luego ponga la unidad a un lado. Taladre un agujero 3/16" (5 mm) de diámetro a través de la pared. Martille el anclaje de pared dentro del agujero hasta que quede alineado. Ponga su unidad en posición y apriete el soporte de pared al anclaje con el tornillo.

## Página 25

Asegúrese de que el surco en los laterales de la gaveta esté centrado con respecto al surco en el frontal de la gaveta.

## Página 28

Fije las correderas primero y luego las perillas.

## Página 29

Nota: los agujeros del soporte de la gaveta son ranurados. Los frentes de las gavetas se pueden ajustar aflojando los tornillos, haciendo los ajustes necesarios y volviendo a apretar los tornillos.

## Página 30

### CARGA MAXIMA

Esta unidad ha sido diseñada para soportar las cargas máximas mostradas. Sobrepassar dichos límites de carga podría ocasionar hundimientos, inestabilidad, colapso del producto y/o lesiones graves.

**Advertencia: riesgo de lesiones personales - no coloque televisores sobre este mueble. Este mueble no está aprobado para ser usado con un televisor.**

## Página 31

Registre su producto para recibir lo siguiente:

- \* Detalles de nuevas tendencias - Vistazo a lo nuevo
- \* Encuestas - aloc su voz entre su comunidad
- \* Códigos de ofertas y descuentos exclusivos
- \* Fácil y rápido servicio de partes de remplace

Para registrar su producto, visite [ameriwoodhome.com](http://ameriwoodhome.com)

Clasificación de 5 estrellas

Visite el sitio web de su tienda local, califique su comprado y denos sus comentarios!

Nos gustaría enviar un gran "Agradecimiento" a todos nuestros clientes por tomarse el tiempo de ensamblar este producto de Ameriwood Home, y por darnos sus valiosos comentarios.

Gracias

## Couverture Avant

CE LIVRET D'INSTRUCTION CONTIENT DES INFORMATIONS **IMPORTANTES** SUR LA SÉCURITÉ. VEUILLEZ LIRE ET GARDER POUR UNE RÉFÉRENCE FUTURE

**Ne retournez pas ce produit!** Contactez notre équipe de service à la clientèle amicale d'abord pour obtenir de l'aide.

**Appelez-nous:** 1-800-489-3351 (sans frais) du Lundi au Vendredi de 9h à 17h Heure Centrale

**Visitez:** [www.ameriwoodhome.com](http://www.ameriwoodhome.com)

## ATTENTION

Le meuble peut basculer et causer des blessures graves ou la mort.

Ancrer le meuble à une planche murale dans le mur (si indiqué).

Ne laissez pas les enfants grimper sur le meuble.

Placez les articles lourds sur les étagères ou dans les tiroirs inférieurs.

## Astuces Utiles (page 2)

- Ouvrez votre article dans la zone que vous prévoyez de le garder pour moins de levage lourd
- Identifier, trier et compter les pièces avant d'essayer d'assembler
- Les goujons de compression sont taraudés avec un Marteau
- Les glissières sont marquées d'un R (droit) et d'un L (gauche) pour un bon placement
- Assurez-vous toujours de faire face la pointe situé sur le haut de la Serrure de Came vers le bord extérieur
- Utiliser tous les clous fournis pour le panneau arrière et les répartir également
- Le panneau arrière doit être utilisé pour vous assurer que votre appareil est robuste
- N'utilisez pas de produits chimiques agressifs ou de nettoyeurs abrasifs sur cet appareil
- Ne jamais pousser, tirer, ou faire glisser votre meuble

## Avant de Commencer (page 3)

- Lisez attentivement chaque étape et suivez le bon ordre
- Séparez et comptez toutes vos pièces et matériaux
- Donnez-vous suffisamment de place pour l'assemblage
- Avoir les outils suivants: tournevis à tête plate, #2 tournevis Phillips, et Marteau
- Attention: Si vous utilisez une perceuse électrique ou un tournevis électrique pour visser, veillez à ralentir et arrêter lorsque la vis est bien serrée. Le non-respect de cette consigne peut endommager la vis.

## Système de Fixation de Came (page 3)

Ce Système de Fixation de Came sera utilisé tout au long de l'assemblage

## Page 13/16

Assurez-vous que le connecteur (4) est positionné comme indiqué avant de l'insérer dans le trou. Tapez avec un marteau pour l'enfoncer complètement.

## Page 18

Remarque :

Le trou est situé en haut à l'arrière.

## Page 23

### **Pour les murs en maçonnerie, béton ou autres matériaux :**

Consultez votre quincaillerie locale pour vous procurer des dispositifs adéquats d'ancrage au mur afin de fixer solidement l'équerre de sécurité.

**IMPORTANT :** CE MEUBLE DOIT ÊTRE FIXÉ AU MUR POUR EMPÊCHER QU'IL NE BASCULE. SUIVEZ CES INSTRUCTIONS POUR INSTALLER L'ÉQUERRE DE SÉCURITÉ ANTIBASCULEMENT FOURNIE AVEC CE PRODUIT.

### **AVERTISSEMENT**

**Le basculement d'un meuble peut entraîner des blessures graves ou mortelles par écrasement.**

#### **Pour empêcher le basculement :**

- \* Installez le dispositif de fixation antibasculement fourni.
- \* Placez les objets les plus lourds dans les tiroirs du bas.
- \* À moins que le meuble ne soit spécifiquement conçu pour en accueillir, ne posez pas de téléviseurs ou autres objets lourds sur ce produit.
- \* Ne laissez jamais les enfants grimper sur les tiroirs, la porte ou les étagères, ou s'y suspendre.
- \* N'ouvrez jamais plus d'un tiroir à la fois.

**Il est possible que l'utilisation de dispositifs de fixation antibasculement ne fasse que réduire le risque de basculement, mais pas l'éliminer.**

#### **OPTION n° 1 : fixation dans un poteau mural (méthode préférée)**

À l'aide d'un détecteur de montants, trouvez un poteau mural. Placez votre meuble contre le mur, avec l'équerre de sécurité alignée à cet endroit. Pour faciliter l'insertion de la vis, vous pouvez percer un trou de guidage de 3 mm de diamètre dans le montant à travers l'équerre de sécurité. Vissez la vis dans le poteau mural à travers l'équerre de sécurité.

#### **OPTION n° 2 : fixation dans une cloison sèche**

Placez votre meuble contre un mur à l'endroit de votre choix et faites une marque sur le mur à travers l'équerre de sécurité, puis déplacez le meuble sur le côté. Percez un trou de 5 mm de diamètre dans le panneau mural. Enfoncez l'ancrage mural dans le trou jusqu'à ce qu'il affleure. Mettez votre meuble en place et fixez l'équerre murale à l'ancrage mural à l'aide de la vis.

## Page 25

Assurez-vous que la rainure des côtés du tiroir est alignée avec celle de la façade du tiroir.

## Page 28

Fixez d'abord les coulisses, puis les poignées.

## Page 29

Remarque : les trous des supports de tiroir sont fendus. Les façades des tiroirs peuvent être ajustées en desserrant les vis, en effectuant les ajustements nécessaires, puis en resserrant les vis.

## Page 30

### CHARGES MAXIMALES

Ce meuble a été conçu pour supporter les charges maximales indiquées. Le dépassement de ces dernières pourrait entraîner un affaissement, une instabilité, un effondrement du produit et/ou des blessures graves.

**Avertissement : risque de blessure pour les personnes - ne placez pas de téléviseur sur ce meuble. Il n'est pas approuvé pour un usage avec un téléviseur.**

## Page 31

Enregistrez votre produit pour recevoir les éléments suivantes:

- \* Détails sur les nouvelles tendances - un aperçu sur les nouveautés
- \* Sondages - avoir une voix au sein de notre communauté
- \* Offres exclusives et codes promo
- \* Service de pièces de rechange rapide et facile

Pour enregistrer votre produit, visitez [ameriwoodhome.com](http://ameriwoodhome.com)

### 5 Étoiles

Visitez le site Web de votre détaillant local, évaluez votre produit acheté et laissez-nous quelques commentaires !

Nous tenons à offrir un grand "Merci" à tous nos clients pour avoir pris le temps d'assembler ce produit "Ameriwood Home", et de nous donner vos commentaires précieux.

Merci